

INCLINATOR ELEVETTE®

Planning Guide

**CABLE DRUM
1000 lb.
(454 Kg)**

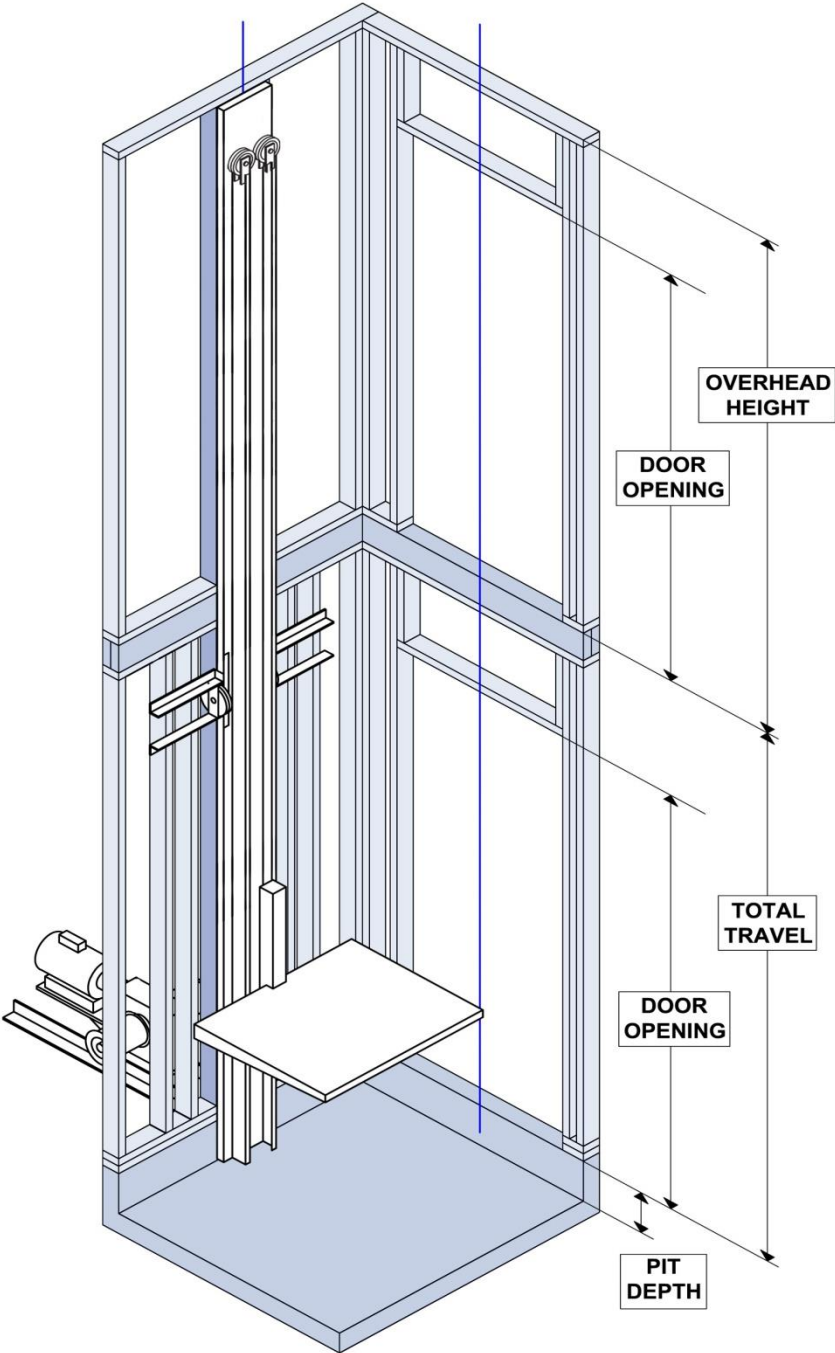

AMERICA'S MOST CUSTOMIZABLE ELEVATOR
INCLINATOR
COMPANY OF AMERICA



This page intentionally left blank.



Table of Contents

Introduction.....	4
Planning Steps for an Inclinator Elevette	5
Hoistway Layout	6
Hoistway Construction.....	11
Flush Mount Door Kit.....	12
Alternate Hoistway Construction	13
Technical Specifications	13
Hoistway Specifications.....	14
Hoistway Elevation	15
Machine Room Configurations	17
Gearbox Assembly	20
Travel Sheaves.....	20
Hall Call Stations	21
UC601 Cable Lengths and Components.....	22
Warranty	23



Introduction

It started over 90 years ago with a passion to help an ailing friend access his multi-level home. Now, almost a century later, the Inclinor craftsmanship can be found in more North American homes today than any other brand. We want to use our heritage of service to enhance each stage of your building or remodeling experience and to help you create a uniquely personalized elevator for your home.

Of all the stages, none is quite as exciting as the initial design phase. It's where you begin to imagine the possibilities of something that's uniquely yours. A home is personalized by the components you choose to fit your needs.

Our Planning Guide is designed to simplify and assist architects, contractors, home owners and dealers in planning for a home elevator that meets or exceeds the requirements of ASME A17.1-2016 and CSA B44-13.

We recommend you contact an authorized dealer in the area where the elevator will be installed. They will be knowledgeable about local codes and restrictions. Become familiar with all requirements governing the installation and use of elevators. It is extremely important for you to know and adhere to all regulations concerning installation.

This Planning Guide provides nominal dimensions and specifications useful for the *initial* planning of an elevator project. Before beginning actual construction, be sure to contact a local authorized dealer and obtain approval drawings customized with specifications and dimensions for your specific project. Call 1-800-343-9007 to find a local dealer or visit our website, www.inclinor.com. Inclinor elevators manufactured and installed under the proper parameters are warranted for 2 years. We assume no liability for equipment not installed in compliance with national, state, and local codes.



Planning Steps for an Inclinator Elevette

1. Locate local dealer and together determine the following:
 - a. Select a drive system, cab type and design specifications
 - b. Address national, state and local code requirements
 - c. Determine installation parameters of site
2. Obtain approval drawings before building hoistway, doorways, pit and any other construction related to the elevator
3. Coordinate with dealer to order and install the elevator



Hoistway Layout

Cab and Hoistway Depth is always Rail wall to Opposite wall, North to South.

Cab and Hoistway Width is always perpendicular to Depth, East to West.

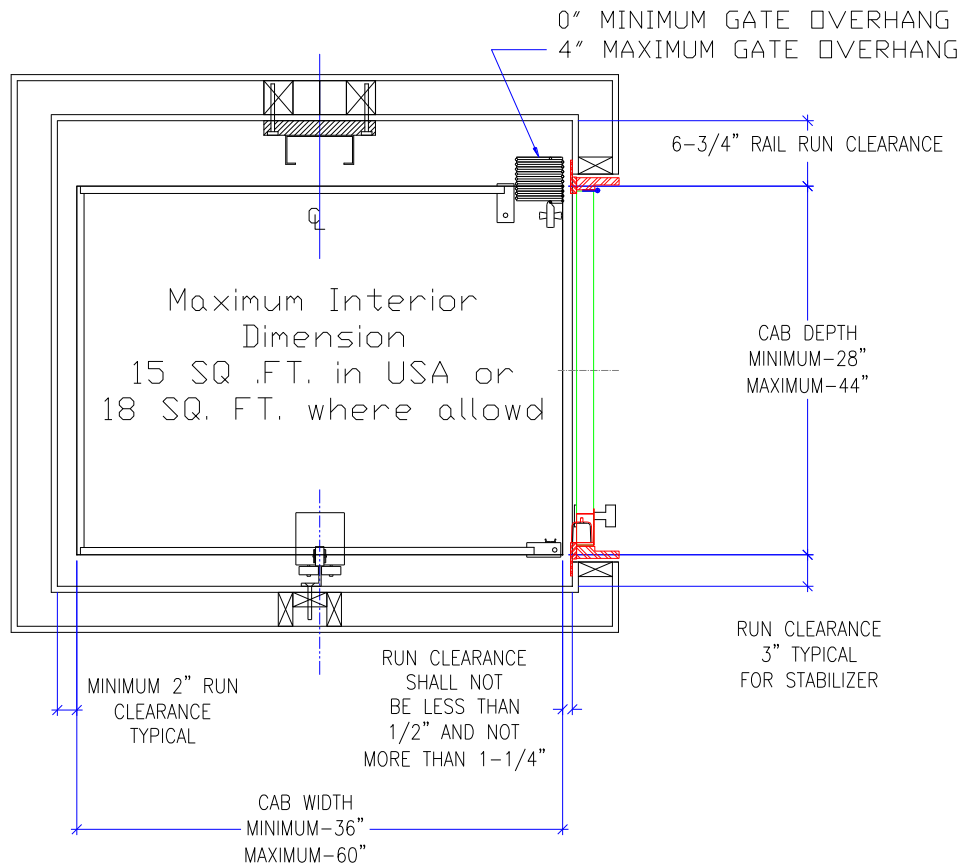

The following specs are to be provided by the General Contractor (GC), except as noted, prior to Elevator Contractor (EC) installing the elevator equipment.

1. Enclosed, plumb and square hoistway with smooth interior surfaces. Include for fascias or furring of hoistway interior.
2. Doors, frames and door hardware.
3. Finish openings as per elevator contractor's shop drawings.
4. Hoistway door security: All hoistway doors require door locking devices (provided by Inclinator) as well as a door handle and a latch set. All doors must be swing type (single hinge). Solid core doors are recommended.
5. Unfinished/Un-installed door: EC may prefer a minimum of one hoistway door and associated framing be left unfinished to accommodate elevator installation and prevent possible damage to door/framing. Preferably at the lowest floor.



Hoistway Layout

The following data is for typical industry size elevators.

Any size cab is available in ¼" increments to dimensions **A** and **C** or **B** and **D** within the maximum and minimum dimensions shown in the diagram on page 6 not to exceed 15 SQ. FT. or 18 SQ. FT. where allowed.

 - Applicable to standard size wheelchairs

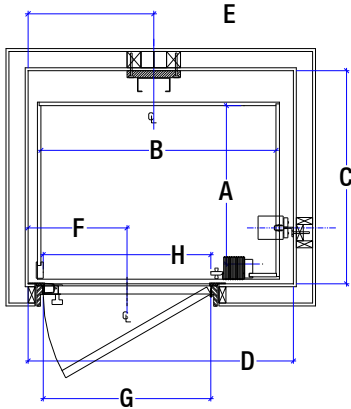

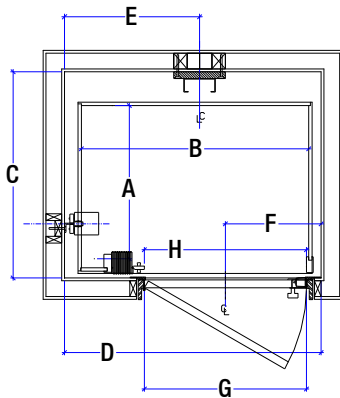

CODE 1

CODE 1	CAR SIZE (O.D.)	A	B	C	D	E	F	G	H
		CAB DEPTH (I.D.)	CAR WIDTH (I.D.)	SHAFT DEPTH	SHAFT WIDTH	CENTER OF RAIL	CENTER OF DOOR	DOOR SIZE	CLEAR OPENING
	38" x 50"	34.25"	48.50"	45.50"	55.00"	27.00"	21.25"	36"	UP TO 40"
	38" x 60"	34.25"	58.50"	45.50"	65.00"	32.00"	21.25"	36"	UP TO 44"
	42" x 48"	38.25"	46.50"	49.50"	53.00"	26.00"	21.25"	36"	UP TO 38"
	42" x 54"	38.25"	52.50"	49.50"	59.00"	29.00"	21.25"	36"	UP TO 44"



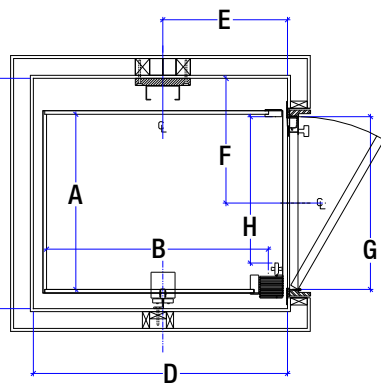

CODE 2

CODE 2	CAR SIZE (O.D.)	A	B	C	D	E	F	G	H
		CAB DEPTH (I.D.)	CAR WIDTH (I.D.)	SHAFT DEPTH	SHAFT WIDTH	CENTER OF RAIL	CENTER OF DOOR	DOOR SIZE	CLEAR OPENING
	38" x 50"	34.25"	48.50"	45.50"	55.00"	28.00"	21.25"	36"	UP TO 40"
	38" x 60"	34.25"	58.50"	45.50"	65.00"	33.00"	21.25"	36"	UP TO 44"
	42" x 48"	38.25"	46.50"	49.50"	53.00"	27.00"	21.25"	36"	UP TO 38"
	42" x 54"	38.25"	52.50"	49.50"	59.00"	30.00"	21.25"	36"	UP TO 44"



CODE 3

CODE 3	CAR SIZE (O.D.)	A	B	C	D	E	F	G	H
		CAB DEPTH (I.D.)	CAR WIDTH (I.D.)	SHAFT DEPTH	SHAFT WIDTH	CENTER OF RAIL	CENTER OF DOOR	DOOR SIZE	CLEAR OPENING
	38" x 50"	36.50"	46.25"	48.00"	52.75"	25.75"	24.00"	32"	UP TO 30"
	38" x 60"	36.50"	56.25"	48.00"	62.75"	30.75"	24.00"	32"	UP TO 30"
	42" x 48"	40.50"	44.25"	52.00"	50.75"	24.75"	26.00"	36"	UP TO 34"
	42" x 54"	40.50"	50.25"	52.00"	56.75"	27.75"	26.00"	36"	UP TO 34"



Hoistway Layout

The following data is for typical industry size elevators.

Any size cab is available in ¼" increments to dimensions **A** and **C** or **B** and **D** within the maximum and minimum dimensions shown in the diagram on page 6 not to exceed 15 SQ. FT. or 18 SQ. FT. where allowed.

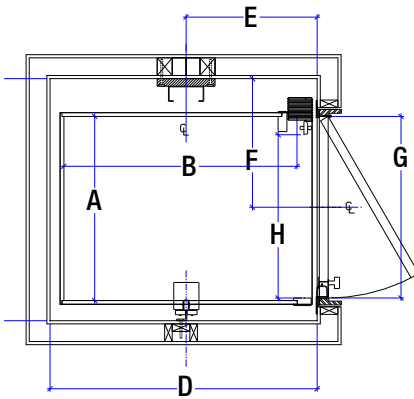

CODE 4

CODE 4	CAR SIZE (O.D.)	A	B	C	D	E	F	G	H
		CAB DEPTH (I.D.)	CAR WIDTH (I.D.)	SHAFT DEPTH	SHAFT WIDTH	CENTER OF RAIL	CENTER OF DOOR	DOOR SIZE	CLEAR OPENING
	38" x 50"	36.50"	46.25"	48.00"	52.75"	25.75"	25.50"	36"	UP TO 32"
	38" x 60"	36.50"	56.25"	48.00"	62.75"	30.75"	25.50"	36"	UP TO 32"
	42" x 48"	40.50"	44.25"	52.00"	50.75"	24.75"	29.50"	36"	UP TO 38"
	42" x 54"	40.50"	50.25"	52.00"	56.75"	27.75"	29.50"	36"	UP TO 38"

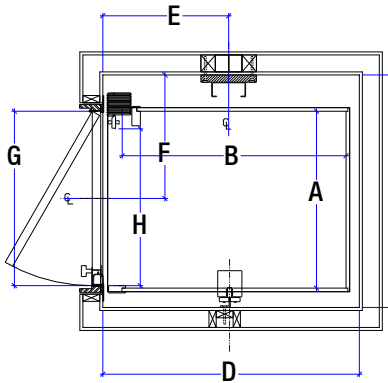

CODE 5

CODE 5	CAR SIZE (O.D.)	A	B	C	D	E	F	G	H
		CAB DEPTH (I.D.)	CAR WIDTH (I.D.)	SHAFT DEPTH	SHAFT WIDTH	CENTER OF RAIL	CENTER OF DOOR	DOOR SIZE	CLEAR OPENING
	38" x 50"	36.50"	46.25"	48.00"	52.75"	25.75"	25.50"	36"	UP TO 32"
	38" x 60"	36.50"	56.25"	48.00"	62.75"	30.75"	25.50"	36"	UP TO 32"
	42" x 48"	40.50"	44.25"	52.00"	50.75"	24.75"	29.50"	36"	UP TO 38"
	42" x 54"	40.50"	50.25"	52.00"	56.75"	27.75"	29.50"	36"	UP TO 38"

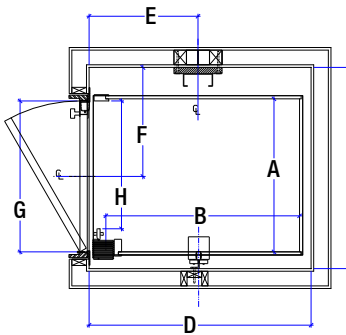

CODE 6

CODE 6	CAR SIZE (O.D.)	A	B	C	D	E	F	G	H
		CAB DEPTH (I.D.)	CAR WIDTH (I.D.)	SHAFT DEPTH	SHAFT WIDTH	CENTER OF RAIL	CENTER OF DOOR	DOOR SIZE	CLEAR OPENING
	38" x 50"	36.50"	46.25"	48.00"	52.75"	25.75"	24.00"	32"	UP TO 30"
	38" x 60"	36.50"	56.25"	48.00"	62.75"	30.75"	24.00"	32"	UP TO 30"
	42" x 48"	40.50"	44.25"	52.00"	50.75"	24.75"	26.00"	36"	UP TO 34"
	42" x 54"	40.50"	50.25"	52.00"	56.75"	27.75"	26.00"	36"	UP TO 34"



Hoistway Layout

Additional configurations available. Consult your dealer or Inclinator for alternate options.

CODE 4,5

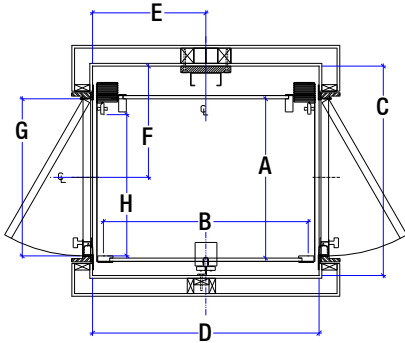

CODE	CAR SIZE (O.D.)	A	B	C	D	E	F	G	H
		CAB DEPTH (I.D.)	CAR WIDTH (I.D.)	SHAFT DEPTH	SHAFT WIDTH	CENTER OF RAIL	CENTER OF DOOR	DOOR SIZE	CLEAR OPENING
♿	38" x 50"	36.50"	44.00"	48.00"	51.50"	25.75"	25.50"	36"	UP TO 32"
♿	38" x 60"	36.50"	54.00"	48.00"	61.50"	30.75"	25.50"	36"	UP TO 32"
♿	42" x 48"	40.50"	42.00"	52.00"	49.50"	24.75"	29.50"	36"	UP TO 38"
♿	42" x 54"	40.50"	48.00"	52.00"	55.50"	27.75"	29.50"	36"	UP TO 38"

CODE 3,6

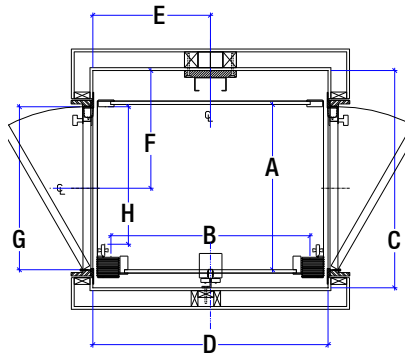

CODE	CAR SIZE (O.D.)	A	B	C	D	E	F	G	H
		CAB DEPTH (I.D.)	CAR WIDTH (I.D.)	SHAFT DEPTH	SHAFT WIDTH	CENTER OF RAIL	CENTER OF DOOR	DOOR SIZE	CLEAR OPENING
	38" x 50"	36.50"	44.00"	48.00"	51.50"	25.75"	24.00"	32"	UP TO 30"
	38" x 60"	36.50"	54.00"	48.00"	61.50"	30.75"	24.00"	32"	UP TO 30"
♿	42" x 48"	40.50"	42.00"	52.00"	49.50"	24.75"	26.00"	36"	UP TO 34"
♿	42" x 54"	40.50"	48.00"	52.00"	55.50"	27.75"	26.00"	36"	UP TO 34"

CODE 5,1

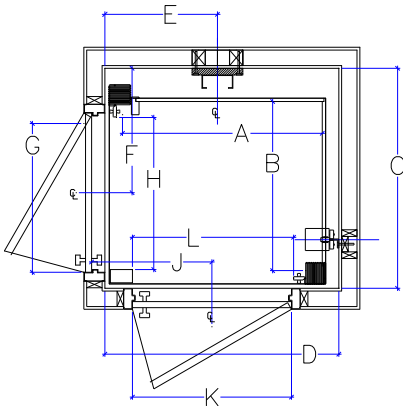

CODE	CAR SIZE (O.D.)	A	B	C	D	E	F	G	H	J	K	L
		CAB DEPTH (I.D.)	CAR WIDTH (I.D.)	SHAFT DEPTH	SHAFT WIDTH	CENTER OF RAIL	CENTER OF DOOR	ADJ. DOOR	CLEAR OPENING	CENTER OF DOOR	OPP. DOOR	CLEAR OPENING
	38" x 50"	34.25"	46.25"	45.50"	53.75"	25.75"	26.00"	32"	UP TO 30"	24.00"	36"	UP TO 38"
	38" x 60"	34.25"	56.25"	45.50"	63.75"	30.75"	26.00"	32"	UP TO 30"	24.00"	36"	UP TO 44"
♿	42" x 48"	38.25"	44.25"	49.50"	51.75"	24.75"	28.00"	36"	UP TO 34"	24.00"	36"	UP TO 36"
♿	42" x 54"	38.25"	50.25"	49.50"	57.75"	27.75"	28.00"	36"	UP TO 34"	24.00"	36"	UP TO 42"

CODE 5,2

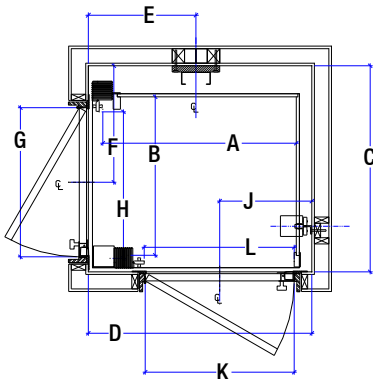

CODE	CAR SIZE (O.D.)	A	B	C	D	E	F	G	H	J	K	L
		CAB DEPTH (I.D.)	CAR WIDTH (I.D.)	SHAFT DEPTH	SHAFT WIDTH	CENTER OF RAIL	CENTER OF DOOR	ADJ. DOOR	CLEAR OPENING	CENTER OF DOOR	OPP. DOOR	CLEAR OPENING
	38" x 50"	34.25"	46.25"	45.50"	53.75"	25.75"	26.00"	32"	UP TO 29"	22.25"	36"	UP TO 36"
	38" x 60"	34.25"	56.25"	45.50"	63.75"	30.75"	26.00"	32"	UP TO 29"	22.25"	36"	UP TO 44"
♿	42" x 48"	38.25"	44.25"	49.50"	51.75"	24.75"	28.00"	36"	UP TO 34"	22.25"	36"	UP TO 34"
♿	42" x 54"	38.25"	50.25"	49.50"	57.75"	27.75"	28.00"	36"	UP TO 34"	22.25"	36"	UP TO 40"



Hoistway Layout

ADDITIONAL CONFIGURATIONS

There are many additional layout options available. Please contact Inclinator or your local dealer for further assistance on shaft configurations.

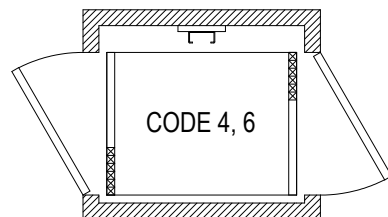
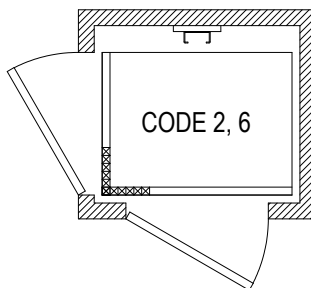
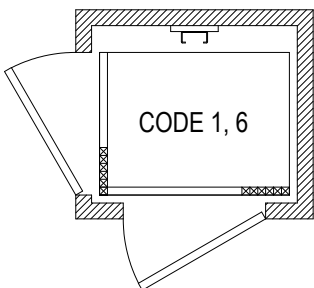
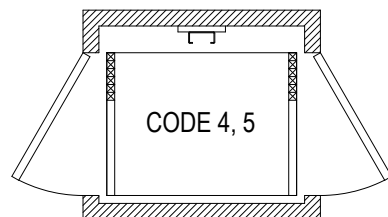
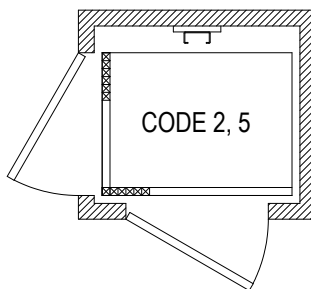
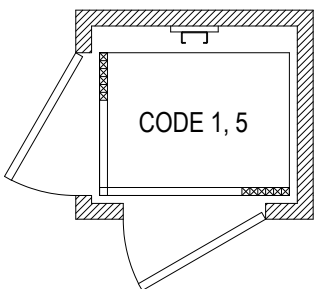
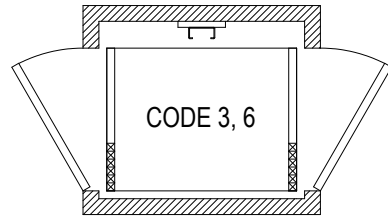
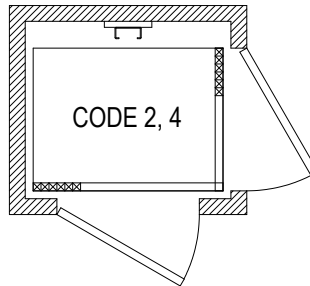
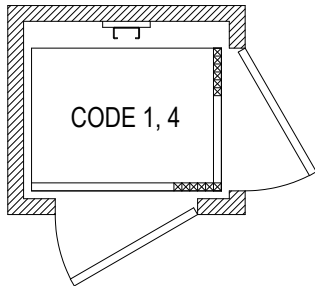
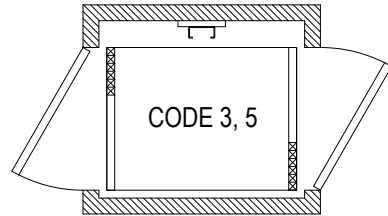
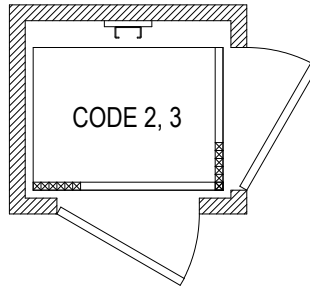
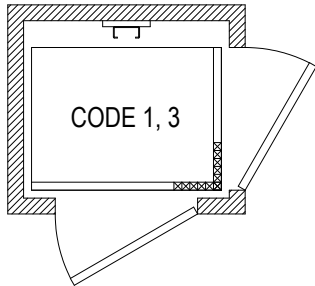

Hoistway Construction

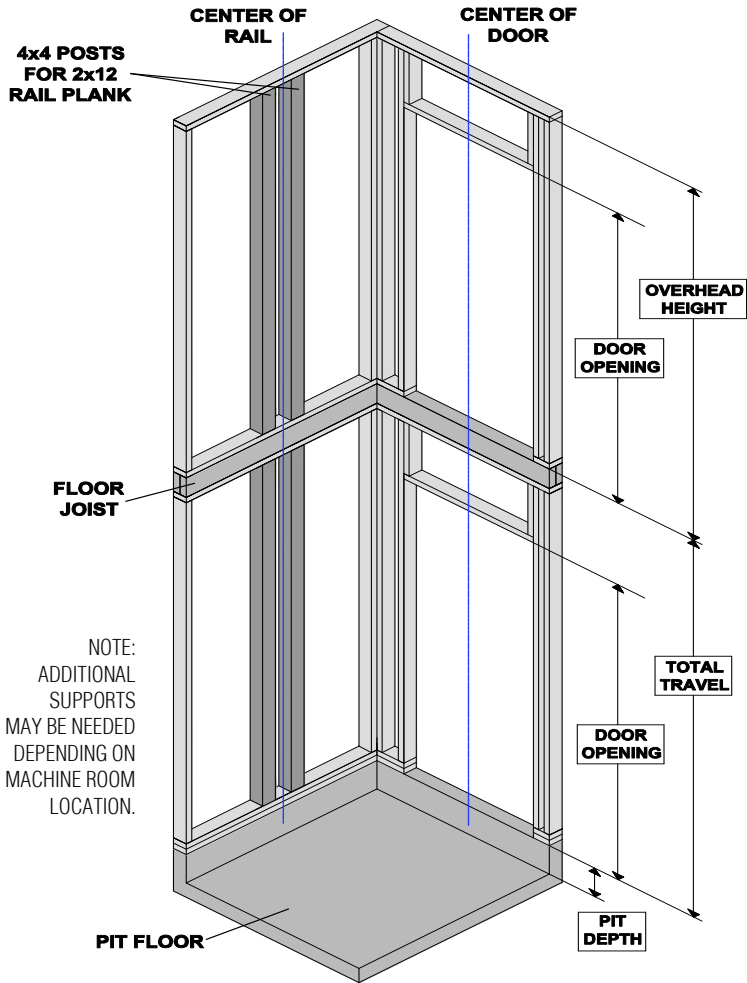

STABILIZER DETAILS

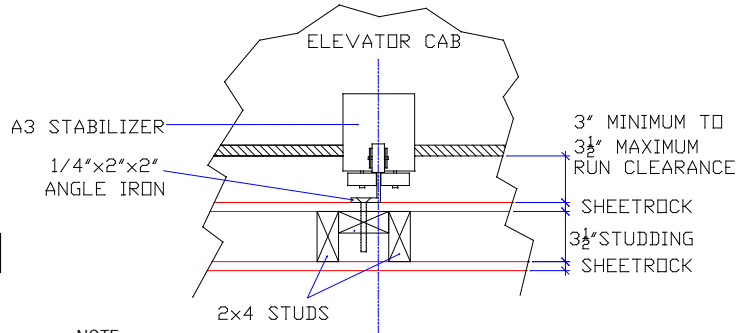

NOTE:
STABILIZER IS MOST COMMONLY PLACED IN MIDDLE OF WALL OPPOSITE THE RAIL. IF THERE IS AN OPENING ON THAT WALL THE STABILIZER MAY BE RELOCATED TO WALL ADJACENT TO THE RAIL.

RAIL DETAILS

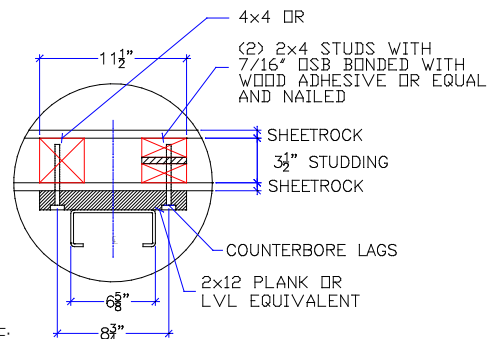

NOTE:
WHEN STUD AND SHEETROCK CONSTRUCTION IS USED ON THE GUIDE RAIL SUPPORT WALL 4"x4" STUDDING IS NEEDED BEHIND THE 2"x12" PLANK.

3/4" X 4" RULE / DOOR FRAME DETAILS

Reference ASME 17.1-2016 5.3.1.4.2, 5.3.1.7.2, & 5.3.1.8.3

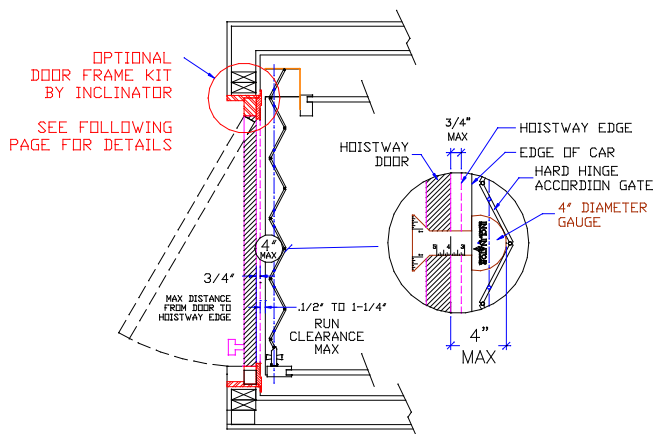

SILL DETAIL

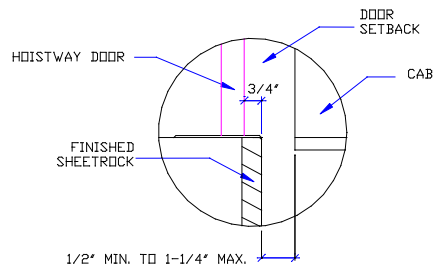

DOOR SILLS TO BE INSTALLED BY G.C. AFTER LIFT SUPPLIER HAS INSTALLED A RUNNING PLATFORM. RUN CLEARANCE TO BE NO LESS THAN 1/2" AND NOT MORE THAN 1-1/4" TO THE RUNNING PLATFORM.



Flush Mount Door Kit

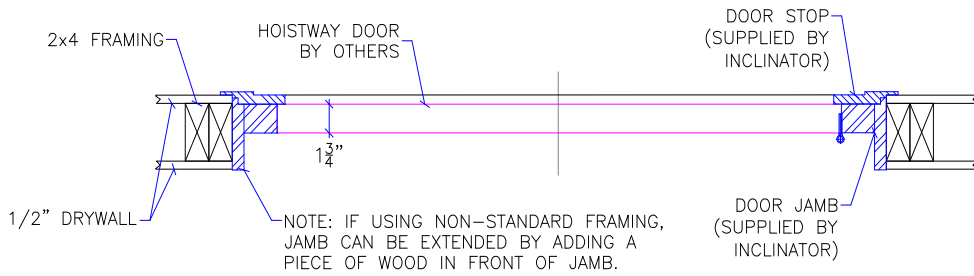

DOOR FRAME DETAIL

STANDARD 2x4 CONSTRUCTION WITH 1/2" DRYWALL (INSIDE & OUTSIDE OF HOISTWAY)

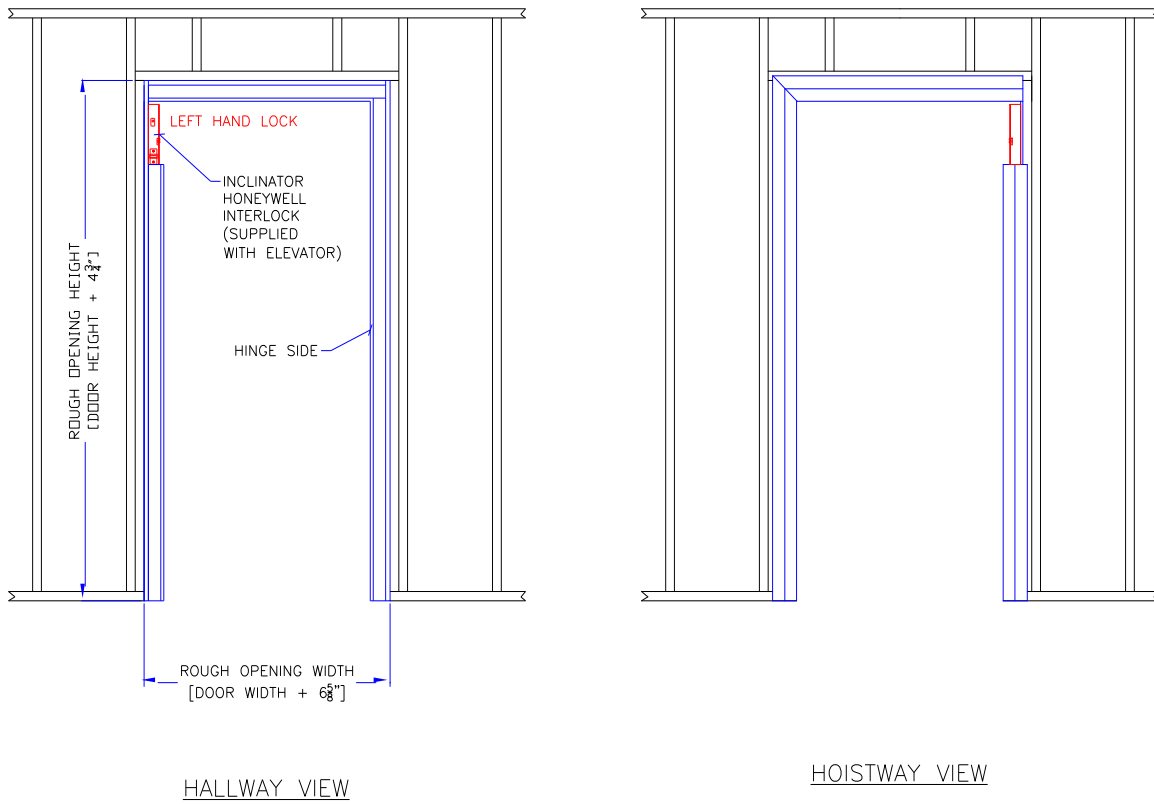

Alternate Hoistway Construction

The following recommendations are for hoistways constructed of concrete or hollow concrete block.

When mounting to a solid concrete wall or solid filled concrete block use (2) concrete screw anchors with a minimum ultimate strength in tension of 3000 lbs (i.e. Redhead LDT – Large Diameter Tapcon) per a mounting bracket.

When mounting to hollow concrete block it is best to use 1/2" threaded rod and thru-bolt the superstrut to the wall. 1/4" Steel plate should be used on the back side of the wall for additional strength.

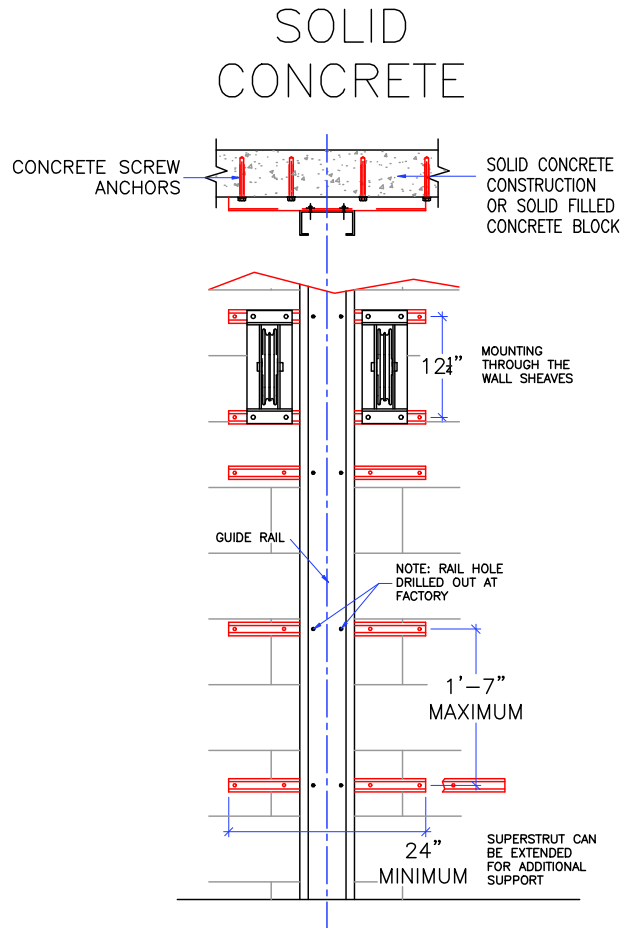
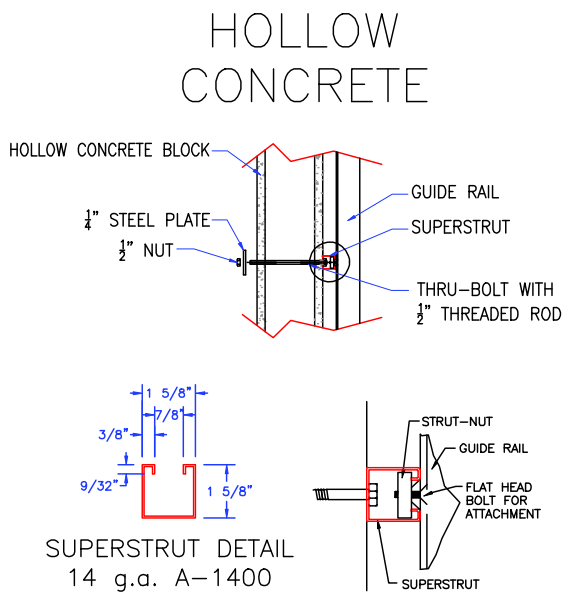

Technical Specifications

1. VERTICAL LOAD FORCES
 STATIC = 1,800 LBS
 IMPACT = 3,600 LBS
2. BOLT FASTENING OF CAR
 TO TROLLEY 1/2" - 13 x 4"
 SOCKET HD CAP SCREWS
3. RAIL FASTENING TO 2"x12" PLANK
 #14 x 1 3/4" TYPE A S.M.S.
 RAIL IS PRE-DRILLED AT FACTORY
4. ALL SHEAVE PITCH DIA. 8 1/8"

NOTE: All mounting points should meet or exceed the minimum pull out force for all rail reactions.

NOTE: Follow the anchor manufacturer's recommendations for type and size of drill bit to be used.



Hoistway Specifications

The following specs are to be provided by the General Contractor (GC), except as noted, prior to Elevator Contractor (EC) installing the elevator equipment.

1. **Environmental requirements** for hoistway:
 - a. Temperature should be maintained between 40⁰ F to 120⁰ F. (4⁰C to 49⁰C)
 - b. Should not be exposed to the elements.
2. **Pit Requirements:**
 - a. Substantial level pit floor slab to support 2,700 lbs. impact load.
 - b. Waterproof pit minimum 8" below lowest floor level.
3. **Overhead Requirements:**

DOOR HEIGHT	INSIDE CAB HEIGHT	OVER ALL CAB HEIGHT	OVERHEAD REQUIREMENT
6' - 8"	80"	7' - 0"	8' - 0"
7' - 0"	84"	7' - 4"	8' - 4"
8' - 0"	92"	8' - 0"	9' - 0"
8' - 0"	96"	8' - 4"	9' - 4"

- a. If minimum 8'0" OH is not possible, consult Inclinator, or EC, about possible solutions.
4. **Rail Wall Requirements:**
 - a. Single steel guide rail (provide by Inclinator) typically to be mounted to a 2"x12" plank, #1 fir or better. Guide rail may also be mounted to superstrut. See drawing details.
 - b. Plank to be installed plumb and straight and shall securely hold the guide rail in a plumb and straight position regardless of car loading.
 - c. Guide rail shall be capable of supporting the loads imposed. Plank shall be fastened with (2) 3/8"x5" lags every 2' OC located at the edge of the plank. Countersink lag heads. 4"x4" studding, or equivalent, behind plank. See drawing detail.
 - d. Studs in rail wall must be of wood unless alternative steel studding is used that contains an inner wood section of equal strength. Studs shall be located per drawing.
 - e. See page 10 for alternate mounting / construction options.
5. **Stabilizer system requirements:** In line studs for stabilizer are to be located opposite rail wall unless code 1 or 2, see drawings.
6. **ASME 17.1 Part 5.3:** Hoistway to be constructed in accordance with this code and all local codes. It is the responsibility of the GC and the EC to comply with all appropriate codes.



Hoistway Elevation

TRAVEL	Minimum Distance from Drum to Sheave
8'-0"	2'-0"
9'-0"	2'-3"
10'-0"	2'-6"
11'-0"	2'-8"
12'-0"	2'-11"
13'-0"	3'-2"
14'-0"	3'-5"
15'-0"	3'-8"
16'-0"	3'-10"
17'-0"	4'-1"
18'-0"	4'-4"
19'-0"	4'-7"
20'-0"	4'-10"
21'-0"	5'-0"
22'-0"	5'-3"
23'-0"	5'-6"
24'-0"	5'-9"
25'-0"	6'-0"
26'-0"	6'-3"
27'-0"	6'-6"
28'-0"	6'-9"
29'-0"	7'-0"
30'-0"	7'-3"
31'-0"	7'-6"
32'-0"	7'-9"
33'-0"	8'-0"
34'-0"	8'-3"
35'-0"	8'-6"
36'-0"	8'-9"
37'-0"	9'-0"
38'-0"	9'-4"
39'-0"	9'-8"
40'-0"	10'-0"

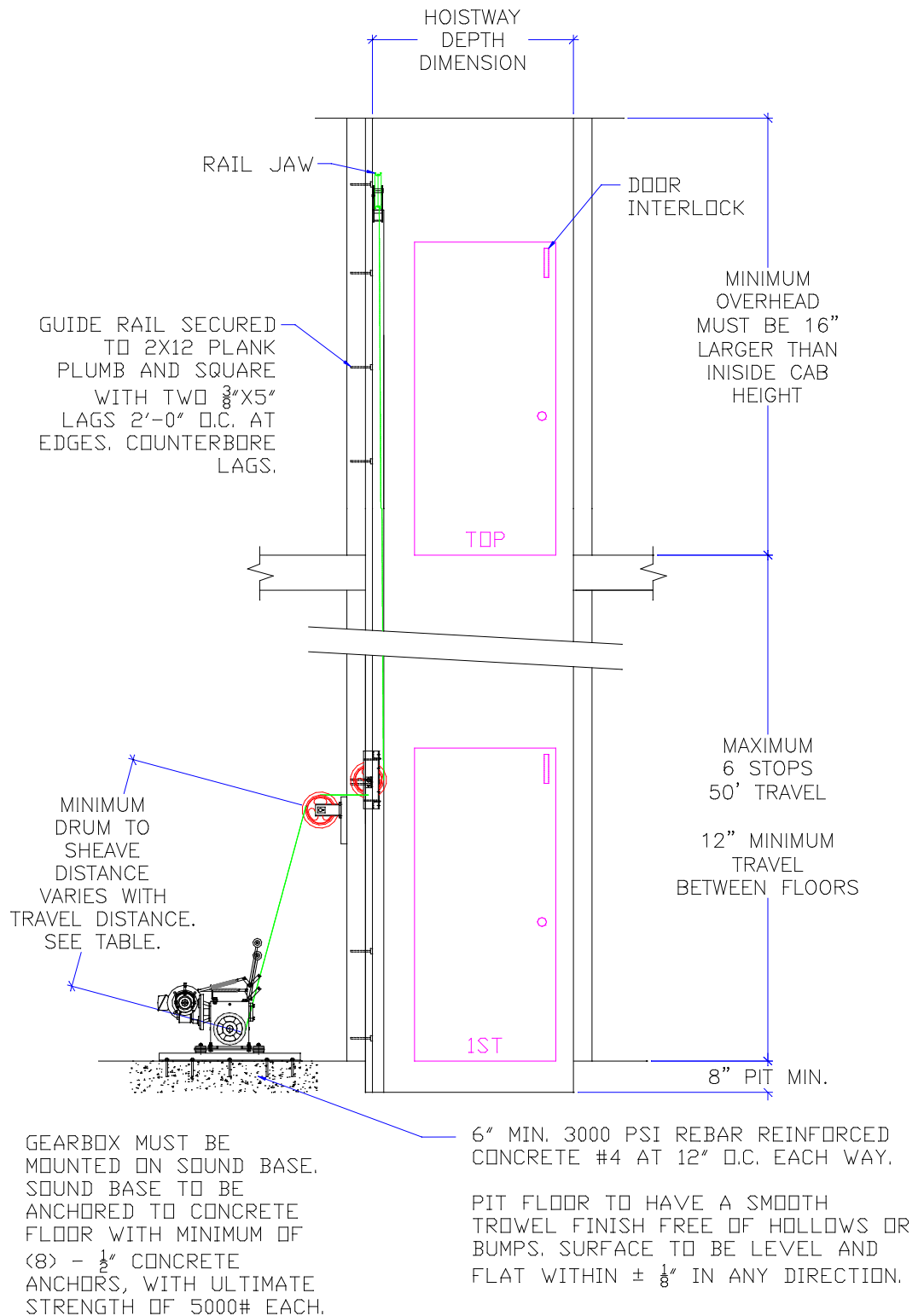

Machine Room Specifications

NOTE: The CPU/Controller and Motor Control is recommended to be mounted in the same location. However, up to 40' controller cables are available if needed.

1. Permanent 230 volt, single phase, 30 amp dedicated supply and disconnect by others to operate the elevator.
2. 120 volt lighting supply and disconnect by others.
3. Telephone connection: Code requires a telephone connection. A phone line must be installed leading to the controller.
4. CPU/Controller and Motor Control should be mounted in a temperature controlled environment between 40° F to 120° F (4°C to 49°C).
5. CPU/Controller and Motor Control should not be exposed to outdoor elements.
6. Typical wiring distance from the Motor Control to the gearbox is 10'. Longer motor cables up to 50' are available. See wiring diagram on page 18 for more information.
7. N.E.C. regulations require a minimum of 30"x36" clear unobstructed floor space in front of the controller. N.E.C regulations also state the floor to ceiling height of the control space should be 6'-6" high.
8. If mounting the CPU/Controller or Motor Control inside the hoistway they should be located in such a way that they can be inspected and maintained without full body entry into the hoistway.

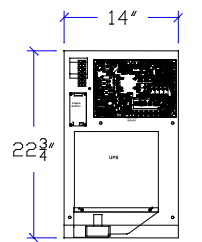
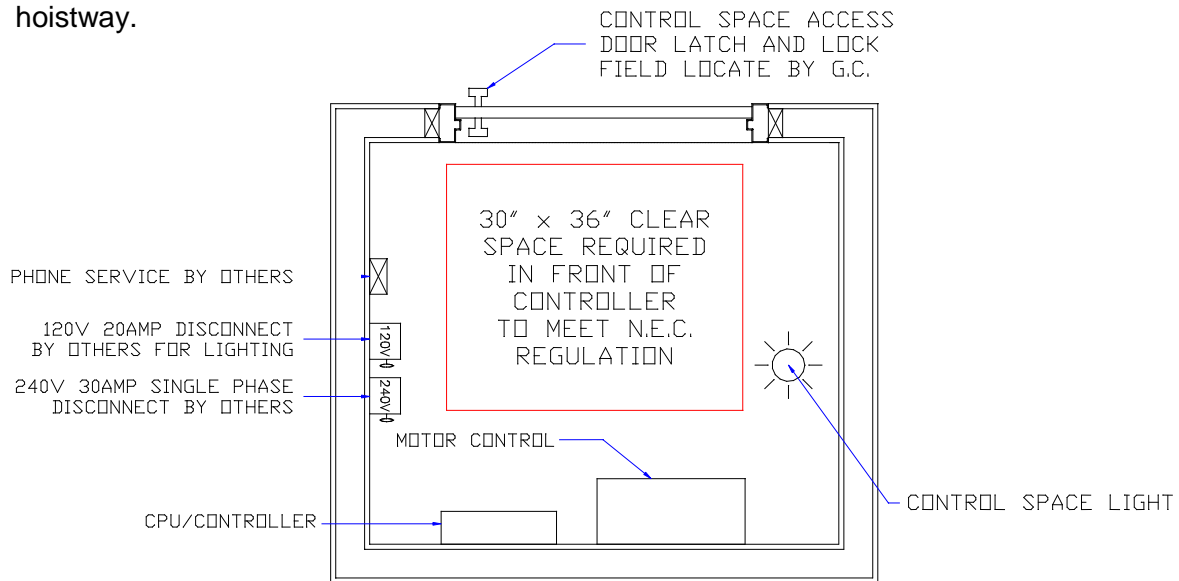

CPU ENCLOSURE
(14"W x 22³/₄"H x 4"D)

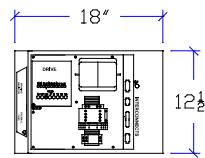

MOTOR CONTROL ENCLOSURE
(18"W x 12¹/₂"H x 8"D)



Machine Room Configurations

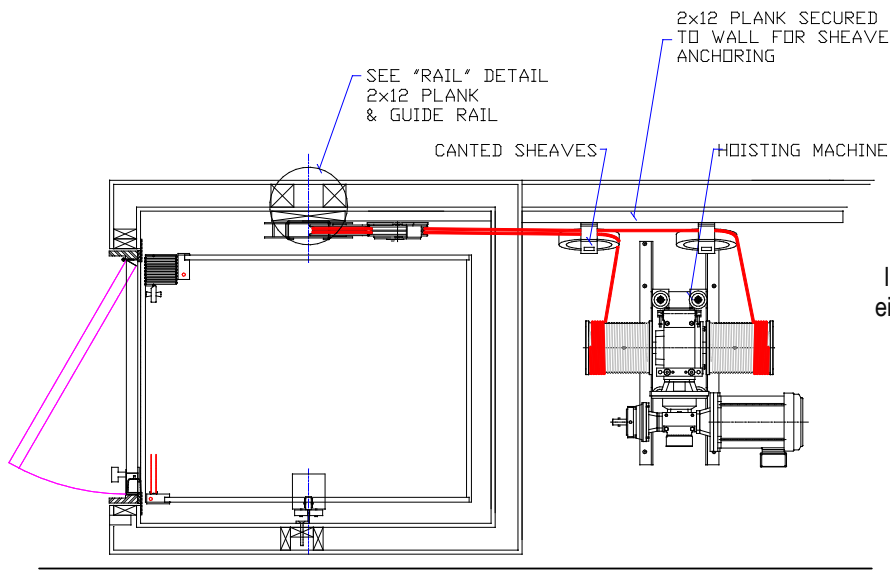

MACHINE ROOM ADJACENT

In this configuration the machine room is located either to the right or left of the guide rail. Requires:

(3) Flat Bracket Sheaves

(1) Rail Jaw

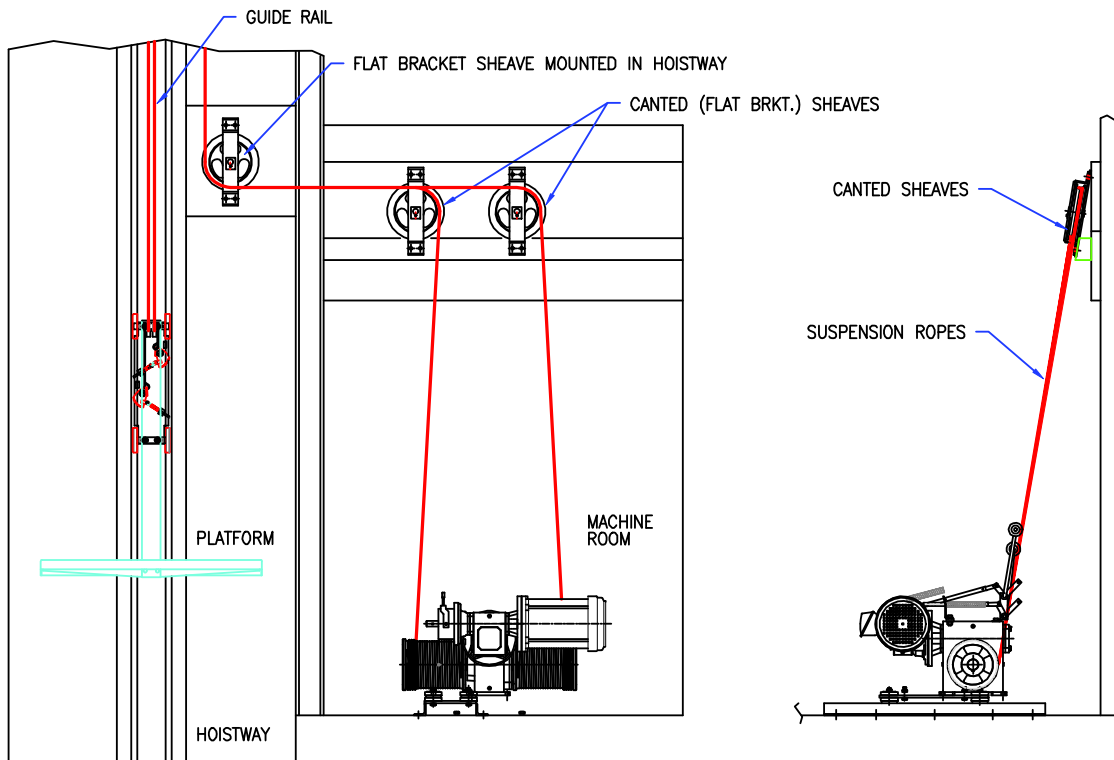
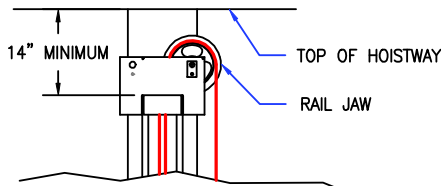

Machine Room Configurations

MACHINE ROOM BEHIND RAIL

In this configuration the machine room is located directly behind the guide rail. Requires:

- (2) Stand Sheaves
- (2) Flat Bracket Sheaves w/ Welded Angle
- (1) Rail Jaw

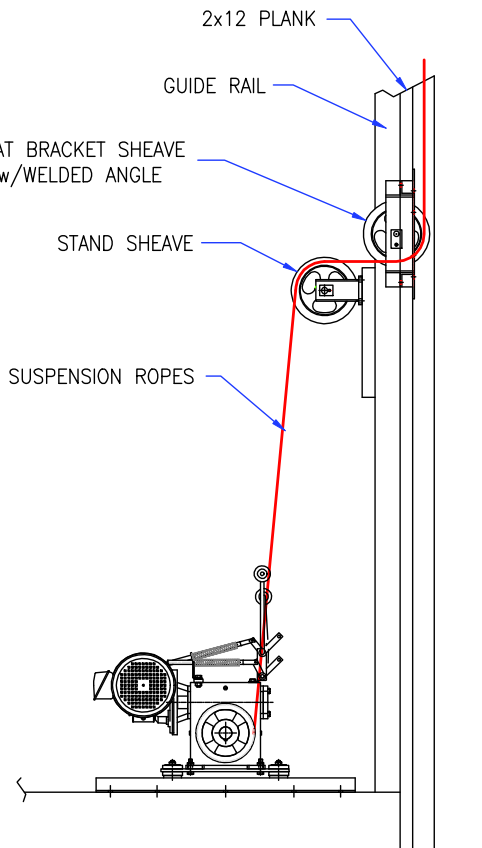
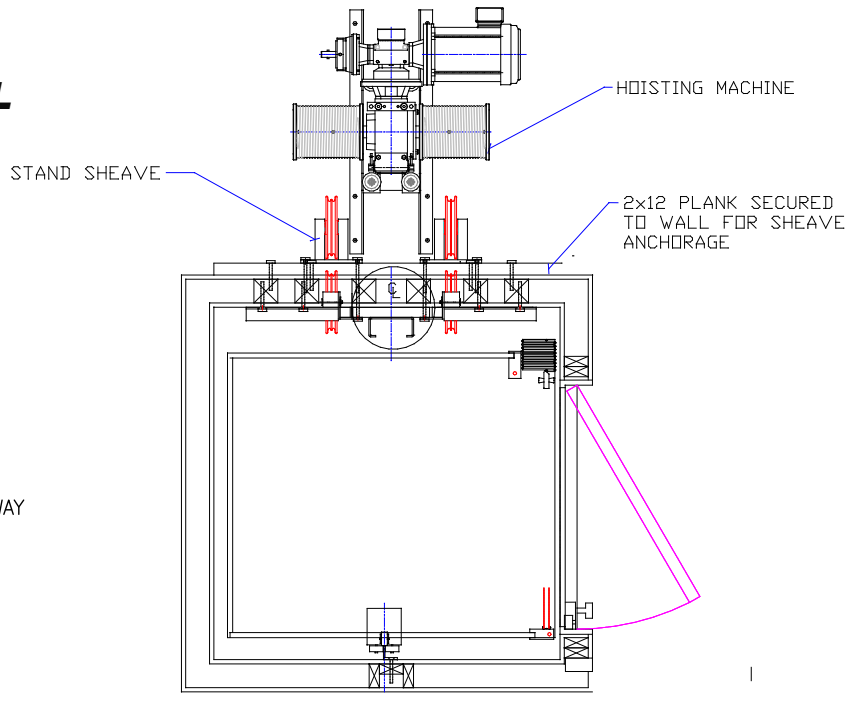
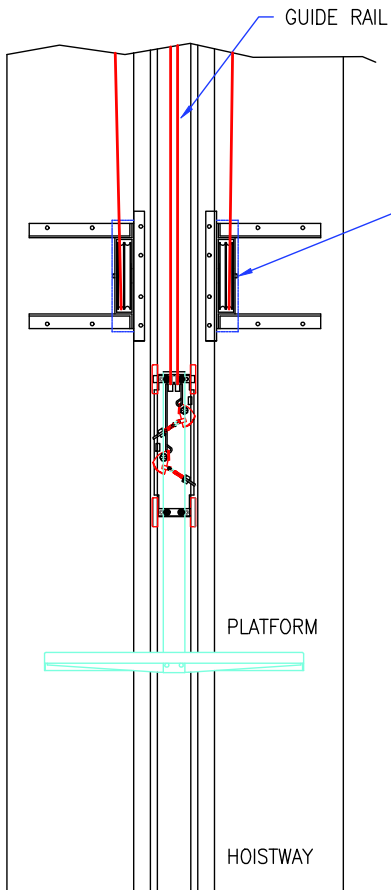
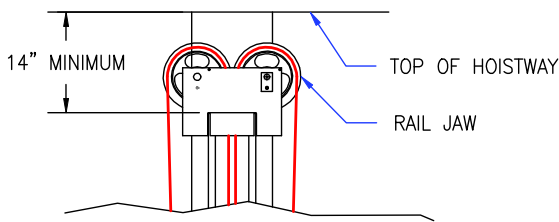

Machine Room Configurations

MACHINE ROOM OVERHEAD

In this configuration the machine room is located overhead in the attic. Requires:

- (2) Flat Bracket Sheaves
- (1) Stand Sheave

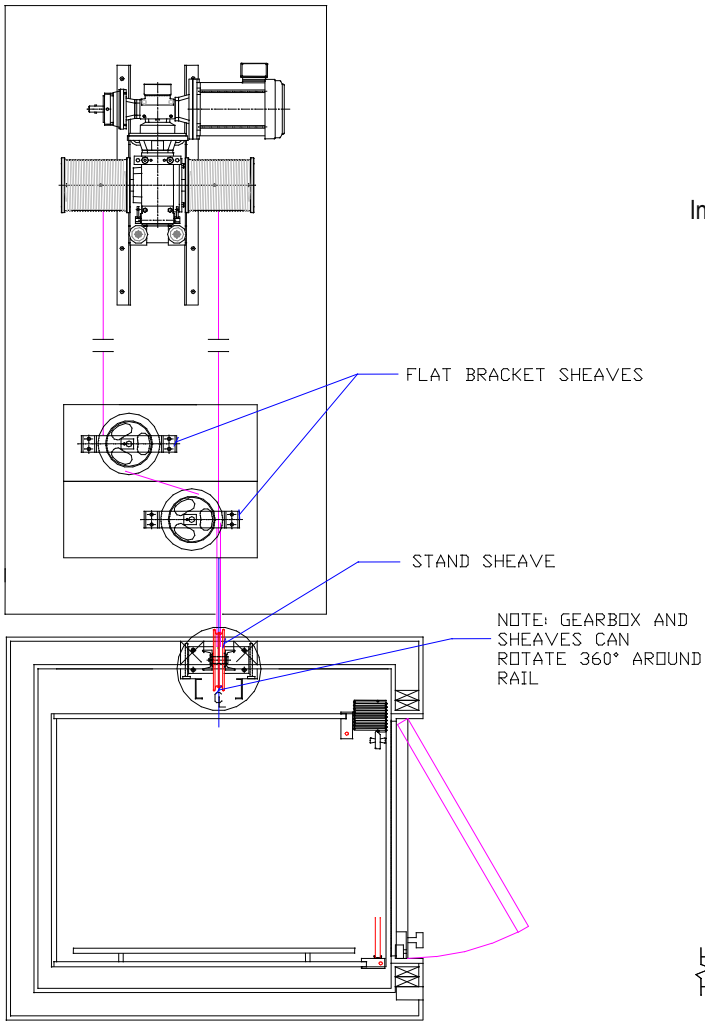

INSTALLATION SHALL BE REVIEWED AND APPROVED BY A STRUCTURAL ENGINEER.

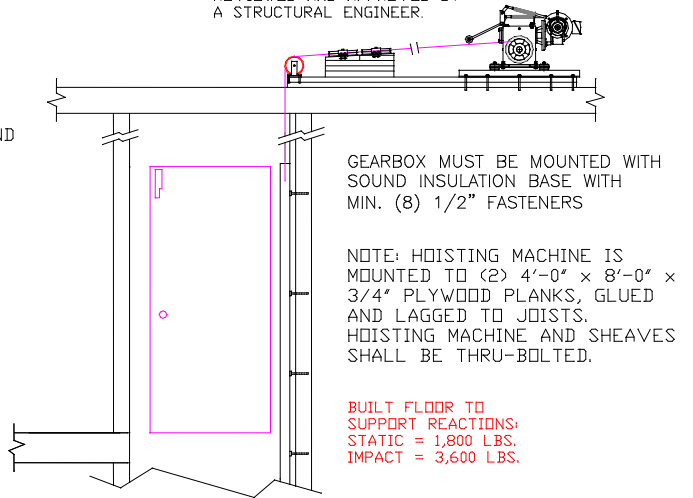

MACHINE ROOM BELOW

In this configuration the machine room is located below the hoistway. Requires:

- (2) Stand Sheaves
- (1) Rail Jaw

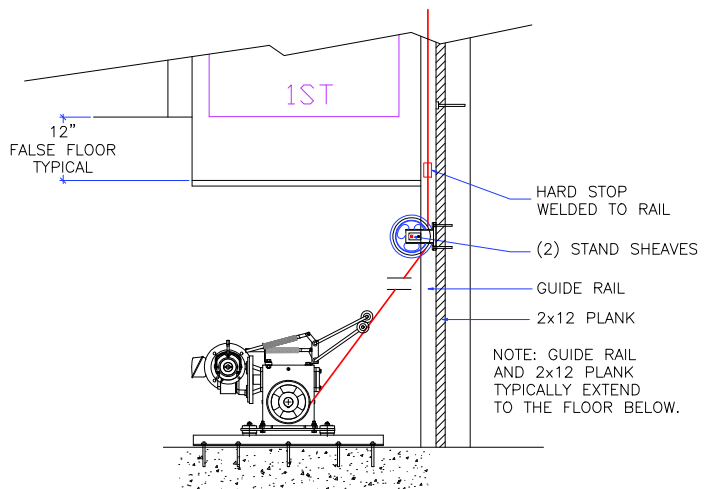

Gearbox Assembly

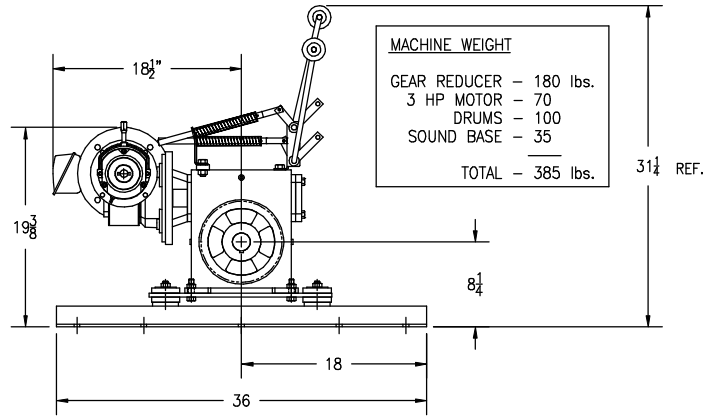
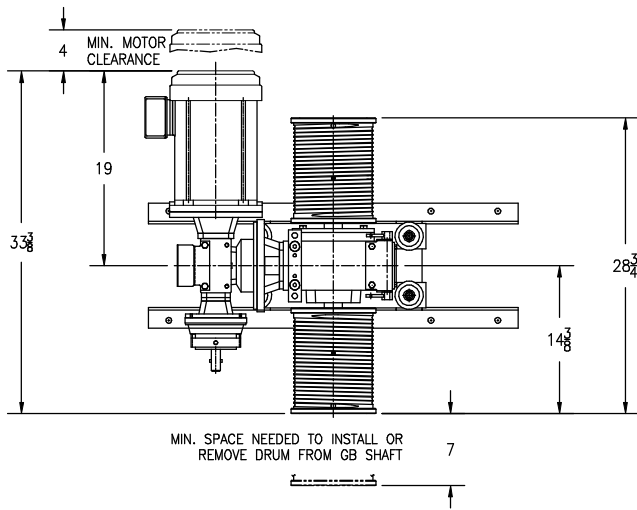

Travel Sheaves

Reactions on all 1000# cable drum sheaves rated at 1800lbs.

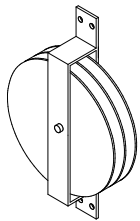

Flat Bracket Sheave

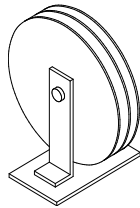

Stand Sheave

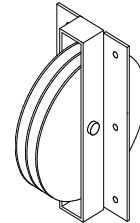

Center of Plank Sheave

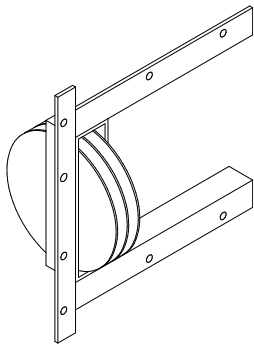

Flat Bracket Sheave With Angle

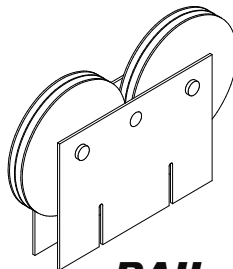

RAIL JAW

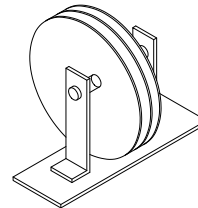

Floating Stand Sheave



Hall Call Stations

FLUSH MOUNT HALL CALL STATION

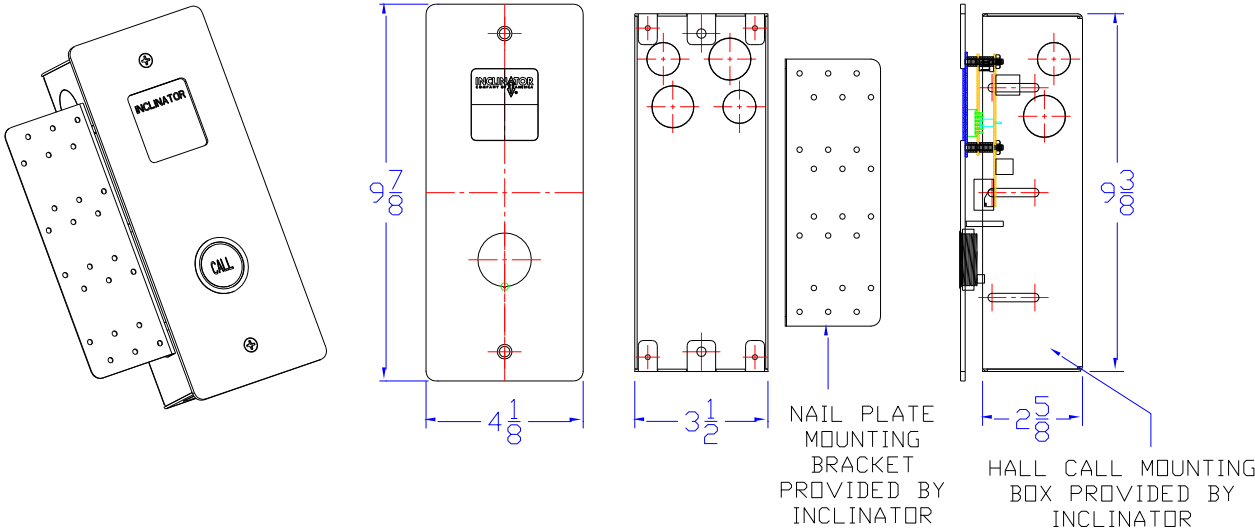

RAISED MOUNT HALL CALL STATION

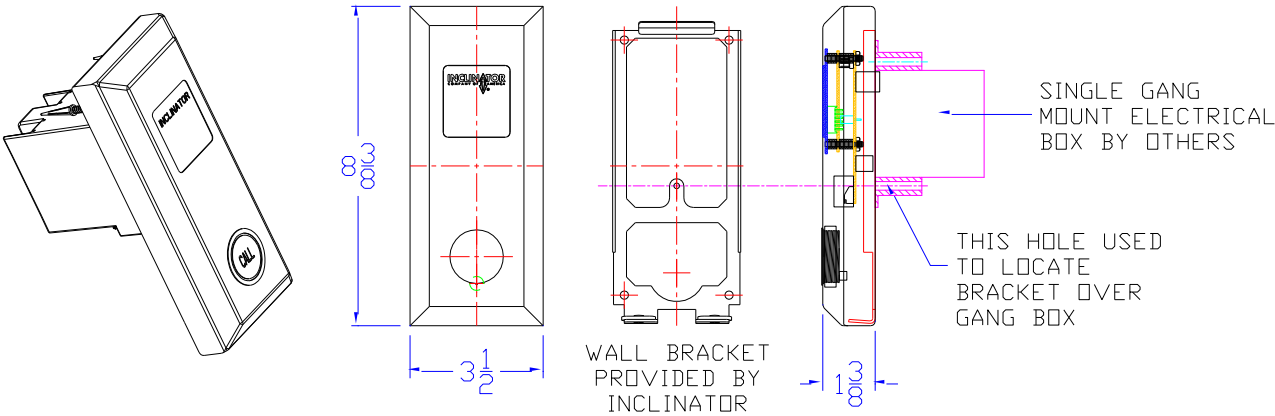

UC601 Cable Lengths and Components

STANDARD MOUNT

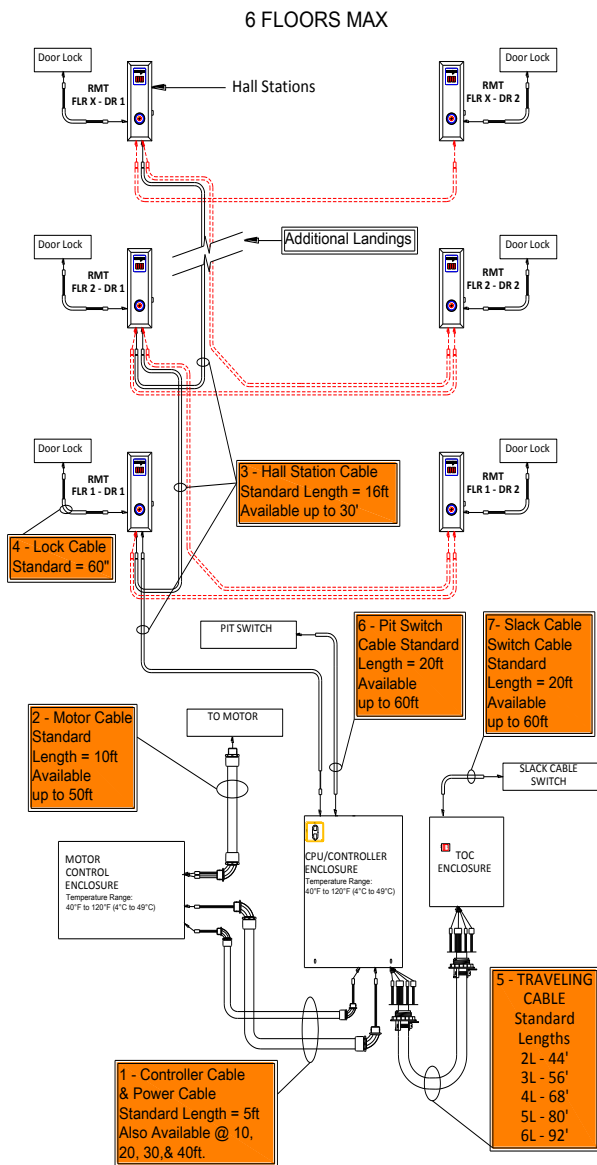

ATTIC MOUNT

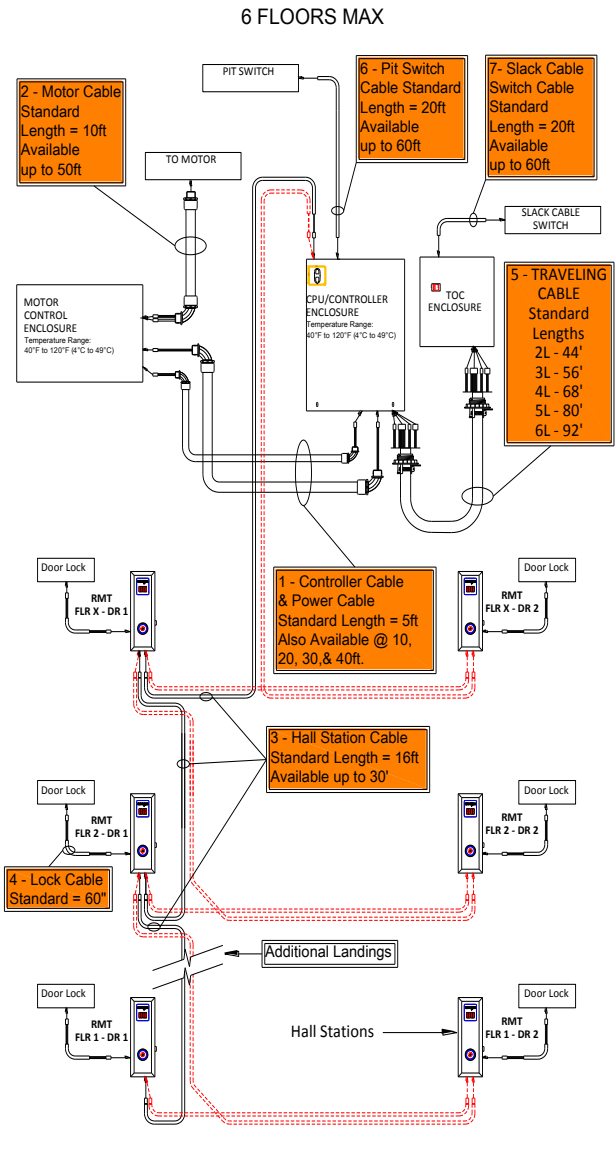

Cable lengths shown are standard based on number of landings ordered. Inclinator offers additional cable length options to meet non-standard installations. Please see order form for additional information on longer cable lengths



Warranty

INCLINATOR COMPANY OF AMERICA – LIMITED PRODUCT WARRANTY

LIMITED PRODUCT WARRANTY OF SELLER; SOLE AND EXCLUSIVE REMEDY

Coverage and length of warranty: This warranty applies to the repair or replacement, at Seller's option, of parts of the Product that fail due to defective workmanship or material. Seller may, at its option, provide factory reconditioned parts. The **basic coverage period for complete units** is twenty-four (24) months from the date that the equipment is shipped from Seller's factory, unless an additional multi-year extended warranty is purchased from Seller in accordance with the extended warranty terms below. The **basic coverage period for Buyer purchased parts**, representing less than a complete unit, is twelve (12) months from the date the part(s) are shipped from Seller's factory (collectively, the Warranty Period).

What is not covered.

- All labor costs that are incurred for removal, repair or replacement of warranty parts, including related travel time.
- Consumable items / parts such as light bulbs, lamps, batteries, UPS (Uninterruptible Power Supplies), oil seals, mechanical switches, guide shoe inserts, drive belts, hydraulic fluid, lubricants, etc.
- Structural or cosmetic components that are subject to normal wear and tear, external forces and/or misuse. This includes paint, stain, caulking, weather barriers, slide blocks, fluid seals, switches, metal panels, glass, Plexiglas, gates, travelling cable, doors, buttons, trim, upholstery, etc.
- Damage or malfunction caused by improper installation and/or repair, lack of maintenance in accordance with manufacturer's recommendations, improper or abnormal use, misuse, neglect, abuse or accident, improper adjustment, structural integrity of building and/or hoistway, exceeding weight limit, failure to follow operating instructions or acts of God.
- Damage or malfunction caused by the integration of any additional parts or items, the customization of any product or parts, and/or the use of non-Inclinators parts, if such integration, customization or use was performed without approval from Seller.
- Damage sustained in shipping. Buyer must file claim with shipping / freight company.

While necessary maintenance or repairs on Seller Product may be performed by any qualified elevator contractor with any appropriate parts, SELLER RECOMMENDS THAT ONLY AUTHORIZED INCLINATOR DEALERS PROVIDE SUCH SERVICES WITH PARTS SUPPLIED BY SELLER. IMPROPER OR INCORRECTLY PERFORMED MAINTENANCE OR REPAIR VOIDS THIS WARRANTY.



THIS WARRANTY IS EXCLUSIVE AND IN LIEU OF ALL OTHER EXPRESS AND IMPLIED WARRANTIES WHATSOEVER, INCLUDING BUT NOT LIMITED TO, THE IMPLIED WARRANTIES OF MERCHANTABILITY AND FITNESS FOR A PARTICULAR PURPOSE, AND IS LIMITED TO A PERIOD OF TWO YEARS (UNLESS EXTENDED) FROM THE TIME THE PRODUCT IS SHIPPED FROM INCLINATOR'S FACTORY.

Buyer shall notify Seller of any warranty claim. Seller will provide a Return Material Authorization (RMA) number, ship replacement part(s) and issue an invoice for part(s) covered under warranty. Replacement part(s) will be shipped to the Buyer using standard shipping practices. Overnight and 2nd day shipment will be billed as an additional charge. Seller may, at its option, provide factory reconditioned parts for replacement. The warranted part(s) shall be returned from the Buyer to the Seller within 60 days from issuance of the RMA. Seller shall confirm that the parts are defective in materials or workmanship within two weeks of receipt from the Buyer and will issue credit for such parts confirmed to be defective. Should such defective parts not be promptly replaced, BUYER'S SOLE AND EXCLUSIVE REMEDY SHALL BE RECOVERY OF THE FULL PURCHASE PRICE OF THAT DEFECTIVE PART.

BUYER EXPRESSLY AGREES THAT THIS REMEDY IS THE SOLE AND EXCLUSIVE REMEDY OF BUYER AGAINST SELLER, AND THAT UNDER NO CIRCUMSTANCES SHALL SELLER BE LIABLE TO BUYER FOR ANY OTHER LOSSES OR EXPENSES, INCLUDING BUT NOT LIMITED TO ANY CONSEQUENTIAL, INCIDENTAL, INDIRECT, CONTINGENT OR PUNITIVE DAMAGES, REGARDLESS OF WHETHER SUCH LIABILITY IS BASED ON BREACH OF CONTRACT, TORT, STRICT LIABILITY, BREACH OF WARRANTIES, FAILURE OF ESSENTIAL PURPOSE, INTELLECTUAL PROPERTY INFRINGEMENT OR OTHERWISE.

FURTHER, SELLER DISCLAIMS LIABILITY FOR ANY PERSONAL INJURY OR PROPERTY DAMAGE RESULTING FROM THE OPERATION OF A PRODUCT THAT HAS NOT BEEN FOUND TO BE DEFECTIVE. IN ADDITION, SELLER DISCLAIMS LIABILITY FOR ANY PERSONAL INJURY OR PROPERTY DAMAGE RESULTING FROM THE OPERATION OF A PRODUCT THAT HAS BEEN MODIFIED FROM THE ORIGINAL SELLER DESIGN OR TO WHICH ANY PARTS OR ITEMS HAVE BEEN ADDED WHETHER SUCH MODIFICATIONS OR ADDITIONS WERE MADE WITH OR WITHOUT THE WRITTEN AUTHORIZATION OF SELLER. NO PERSON OR COMPANY IS AUTHORIZED TO CHANGE THE DESIGN OR MAKE-UP OF THIS PRODUCT WITHOUT WRITTEN AUTHORIZATION BY SELLER.

THIS WARRANTY SUPERCEDES ALL OTHER PUBLISHED, PRINTED OR ORAL WARRANTIES WITH RESPECT TO THE PRODUCT.

EXTENDED WARRANTY Within 120 days from the date of shipment to Dealer, Dealer may purchase an additional multi-year warranty from Seller by signing and fulfilling the terms of the Dealer Extended Product Limited Warranty Purchase Form.

Rev. 2-20-2017



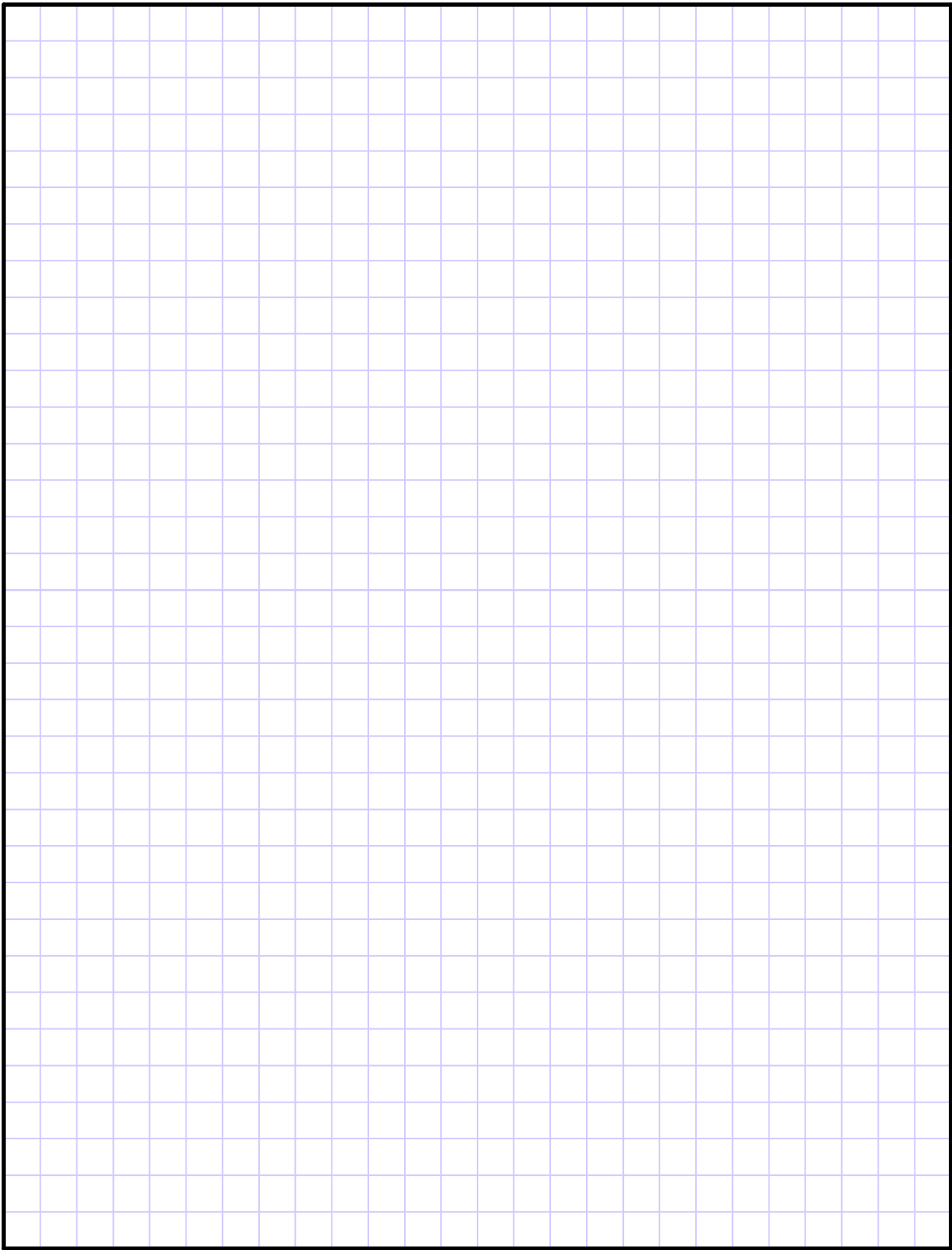



601 Gibson Blvd, Harrisburg, PA 17104 | 800-343-9007 | www.INCLINATOR.com

