

ORDER REFERENCE

PROJECT: 500# DUMBWAITER
MACHINE BELOW

TYPICAL DRAWING FOR REFERENCE ONLY.
NOT TO BE USED FOR CONSTRUCTION

SPECIFICATIONS

MODEL: DW-500 (BI-PARTING DOORS AND GATES)

LANDINGS: 2

OPENING: WEST

CAPACITY: 500#

SPEED: 50 F.P.M.

SUSPENSION MEANS: 1 WIRE ROPE 5,400 LBS. EHS
STEEL 1/4" x 8 x 19 IWRC

CAR CONSTRUCTION: STAINLESS STEEL
OR PAINTED STEEL

NOTE: ALL MANUFACTURER SUPPLIED CAR AND EQUIPMENT OPTIONS ARE NOTED ON THE CONFIRMING ORDER SHEET.

DISCLAIMER: ONCE DRAWINGS HAVE BEEN APPROVED, SIGNED AND WITHIN 5 DAYS OF PRODUCTION, THE CUSTOMER WILL BEAR ALL RESPONSIBILITY AND LIABILITY OF FINISHED UNIT.

PLEASE REFER ANY QUESTION TO YOUR SALES REPRESENTATIVE

APPROVED

UNAPPROVED

SIGNATURE

DATE

DWG VIEW		PART NUMBER			REV. DATE	
COVER SHEET		TYPICAL			-	
		DRAWING TITLE			-	
DW 500 BI-PART OPEN WEST		DRAWING NO.			-	
		DW-011			-	
PAGE:	DRAWN BY:	DWG. DATE	JOB OR APP.#	DEALER P.O.#	DWG. SCALE	REV. LEVEL(1-3)
1/4	B. BRATTEN	JAN. 2014	-	-	1:24	-

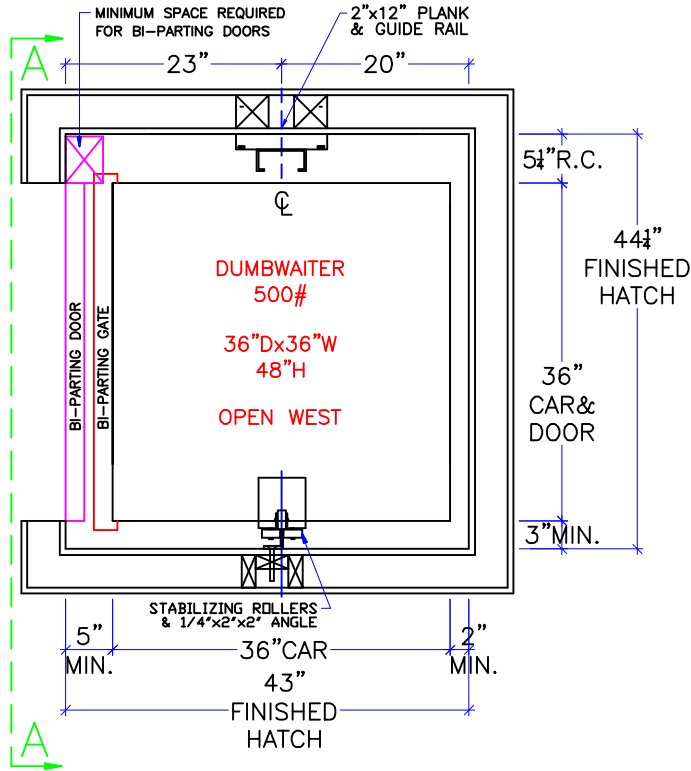

HOISTWAY PLAN

SEE "LOAD CAPACITY CALCULATOR"
FOR OTHER POSSIBLE
DW 500# CAB DIMENSIONS

NOTE:
ALL HOISTWAY CONSTRUCTION MUST COMPLY WITH NATIONAL, STATE,
AND LOCAL CODES. HOISTWAY MUST BE PLUMB AND STRAIGHT FROM
TOP TO BOTTOM WITH NO PROJECTIONS INTO THE HOISTWAY.

NOTICE TO ELECTRICAL CONTRACTOR:

- ALL ELECTRICAL WIRING MUST BE DONE BY A JOURNEYMAN MECHANIC AND MUST MEET ALL NATIONAL, STATE, AND LOCAL CODES.
- BRING (3) #10 W/GND FROM RESIDENCE INCOMING POWER PANEL 30AMP BREAKER(240V, NEUTRAL, GROUND)TO THE MACHINE ROOM.
- BRING (2) #12 W/GND FROM RESIDENCE INCOMING POWER PANEL 20AMP GFI BREAKER(120V, NEUTRAL, GROUND)TO THE MACHINE ROOM.
- REQUIRED LOW VOTAGE WIRING IS SUPPLIED BY MANUFACTURER. ALL EXTENSIONS ADDITIONS, ETC. SHALL BE DONE WITH THE SAME SIZE AND TYPE OF WIRE AS ORIGINALLY SUPPLIED BY THE MANUFACTURER.
- ALL MEANS FOR ACCESS TO EQUIPMENT SHALL BE PROVIDED WITH A LOCK. ALL SHAFT DOORS MUST BE INTERLOCKED.

DWG VIEW HOISTWAY LAYOUT		PART NUMBER TYPICAL		REV.DATE	
DRAWING TITLE DW 500 BI-PART OPEN WEST		DRAWING NO. DW-011		-	
PAGE: 2/4	DRAWN BY: B.BRATTEN	DWG. DATE JAN. 2014	JOB OR APP.# -	DEALER P.O.# -	DWG. SCALE 1:24
					REV.LEVEL(1-3) -



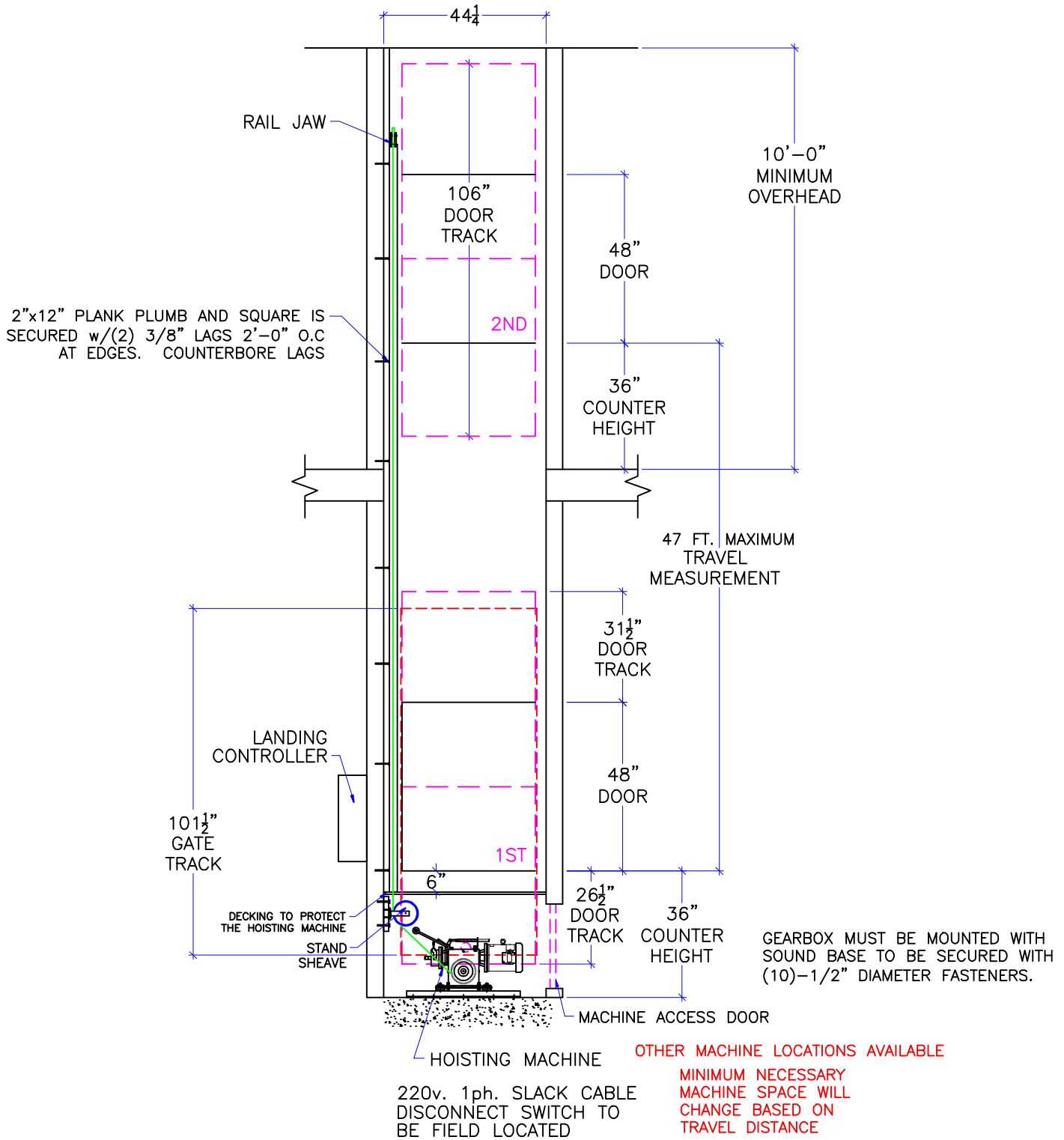

SECTION "A-A"

DWG VIEW		SECTION A-A		PART NUMBER		REV. DATE	
				TYPICAL		-	
		DRAWING TITLE		DRAWING NO.		-	
		DW 500 BI-PART OPEN WEST		DW-011		-	
PAGE:	DRAWN BY:	DWG. DATE	JOB OR APP.#	DEALER P.O.#	DWG. SCALE	REV. LEVEL(1-3)	
3/4	B. BRATTEN	JAN. 2014	-	-	1:24	-	

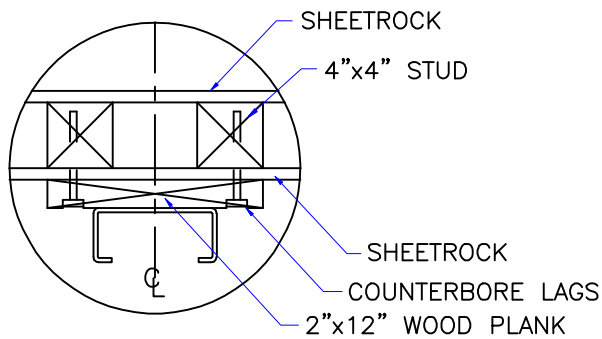

NOTE:
 WHEN STUD AND SHEETROCK CONSTRUCTION IS USED ON THE GUIDE RAIL SUPPORT WALL 4"x4" STUDDING IS NEEDED BEHIND THE 2"x12" PLANK.

RAIL DETAIL

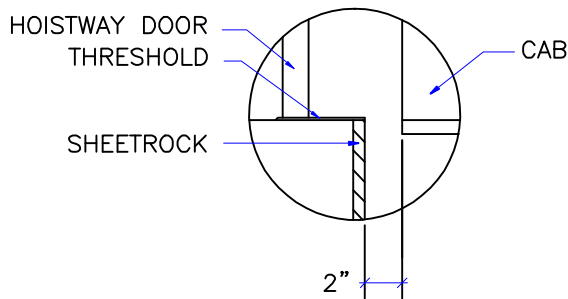

DOOR SILLS TO BE INSTALLED BY G.C. AFTER LIFT SUPPLIER HAS INSTALLED A RUNNING PLATFORM.

SILL DETAIL

FOR DOOR DETAILS
 SEE ATTACHED
 DRAWINGS

DOOR FRAME DETAIL

SEE "LOAD CAPACITY CALCULATOR"
 FOR OTHER POSSIBLE
 DW 500# CAB DIMENSIONS

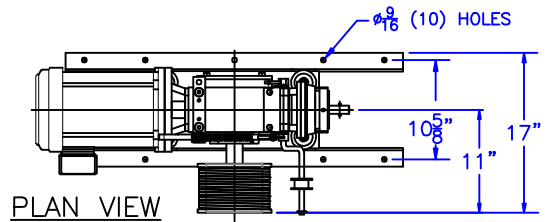

PLAN VIEW

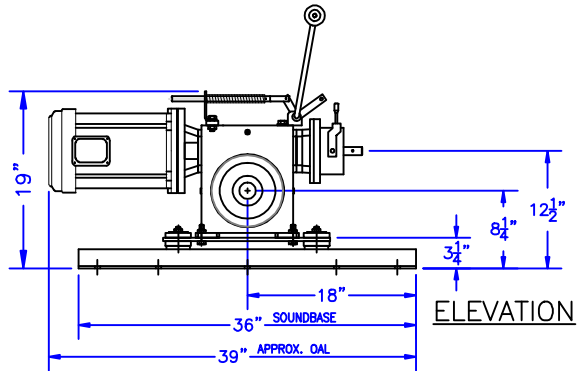

ELEVATION

1. MACHINE ROOM SIZE REQUIREMENTS MAY CHANGE WITH TRAVEL DISTANCE
2. MACHINE ROOM CAN BE LOCATED ABOVE OR BELOW HOISTWAY
3. SHEAVE COMBINATIONS WILL CHANGE WITH ALTERNATE MACHINE ROOM LOCATIONS

500# DUMBWAITER MACHINE DIMENSIONS

1. REACTIONS ON ALL SHEAVES AND MOUNTINGS
 STATIC = 1,100 LBS.
 IMPACT = 2,200 LBS.
2. RAIL FASTENING TO 2" x 12" PLANK
 #14 x 1 3/4" TYPE A S.M.S. RAIL IS PRE-DRILLED AT FACTORY.
3. BOLT FASTENING OF CAR TO TROLLEY
 1/2" - 13 x 2 1/2" SOCKET HD CAP SCREWS.

TECHNICAL DATA

DWG VIEW		PART NUMBER		REV. DATE		
DETAILS, DATA, CODES		TYPICAL		-		
DRAWING TITLE		DRAWING NO.		-		
DW 500 BI-PART OPEN WEST		DW-011		-		
PAGE:	DRAWN BY:	DWG. DATE	JOB OR APP.#	DEALER P.O.#	DWG. SCALE	REV. LEVEL(1-3)
4/4	B. BRATTEN	JAN. 2014	-	-	1:24	-



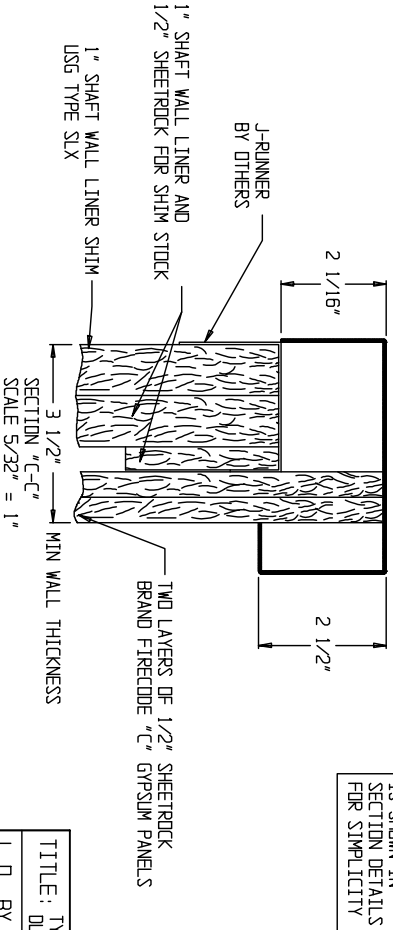
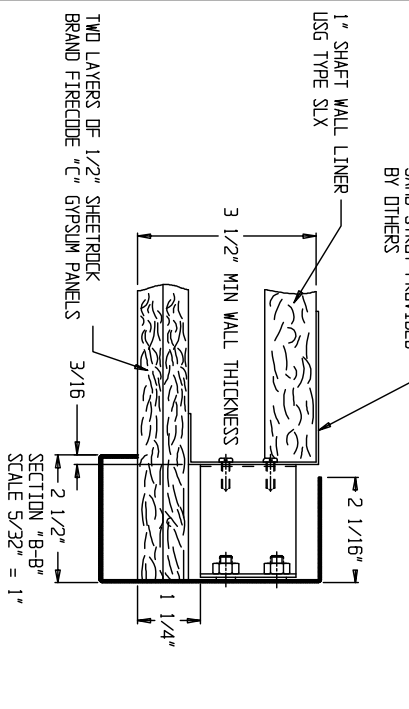
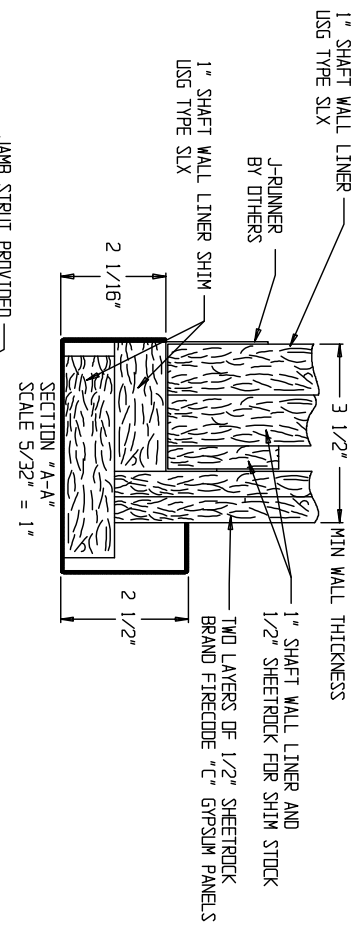

NOTE: AS WALL THICKNESS CHANGES, THE METHOD OF DRYWALL INSTALLATION WILL CHANGE ACCORDINGLY. THIS DRAWING SHOULD BE USED ONLY AS A REFERENCE.

ONLY DOOR FRAME IS SHOWN IN SECTION DETAILS FOR SIMPLICITY

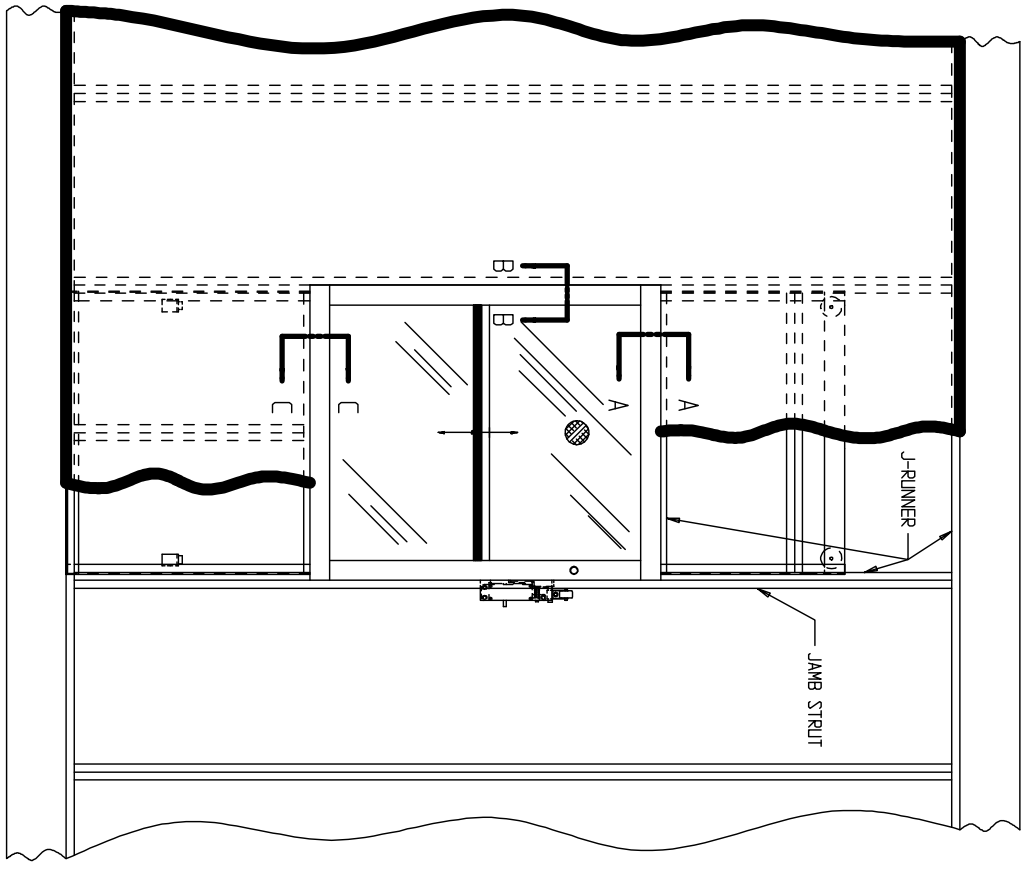

WALL TO BE BUILT TO UNDERWRITERS LABORATORIES STANDARD WA38 HOISTWAY TO BE BUILT BEFORE DUMBWALTER IS INSTALLED EXCEPT THE WALLS ARE TO BE OMITTED WHERE HOISTWAY DOORS OCCUR UNTIL THE DUMBWALTER IS INSTALLED & HOISTWAY DOORS ARE SET IN PLACE

TITLE: TYPICAL VARIATION OF DRYWALL CONSTRUCTION WITH KARKA UL LABELED COUNTER LOADING BY PARTING		LEVEL 1 1/9/06	
L.O. BY	DATE REQ		
APPROVED	PAINT		
DATE L.O.	SHEET 1 OF 1		
SCALE 1/16" = 1"	# REQ'D	-B- JJP	DWG NO. 1000-725
		JOB NO.	

WALL TO BE BUILT TO UNDERWRITERS
LABORATORIES STANDARD W438
WALL DESIGN

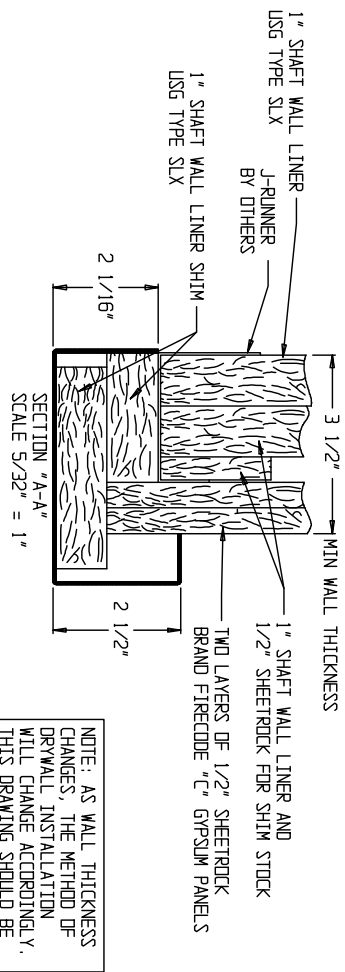

NOTE: AS WALL THICKNESS CHANGES, THE METHOD OF DRYWALL INSTALLATION WILL CHANGE ACCORDINGLY. THIS DRAWING SHOULD BE USED ONLY AS A REFERENCE.

ONLY DOOR FRAME IS SHOWN IN SECTION DETAILS FOR SIMPLICITY

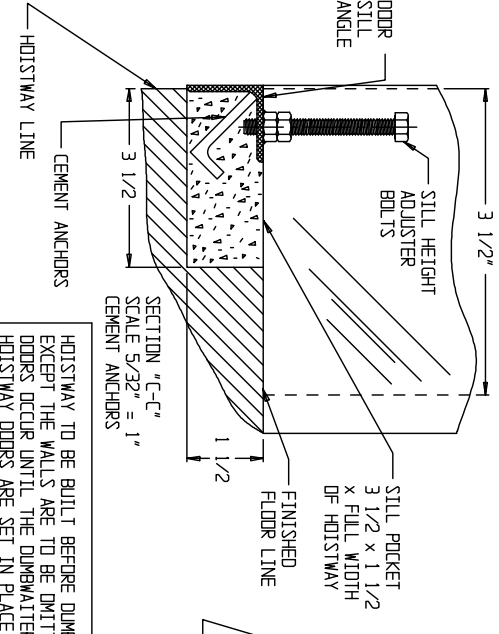
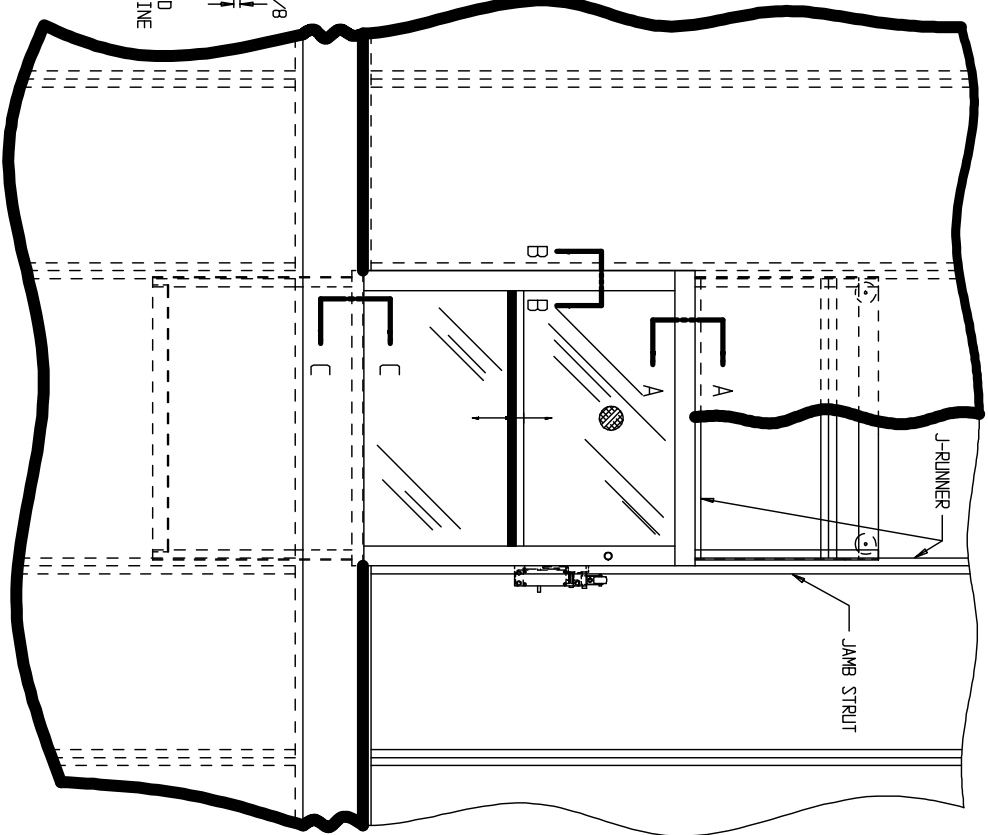
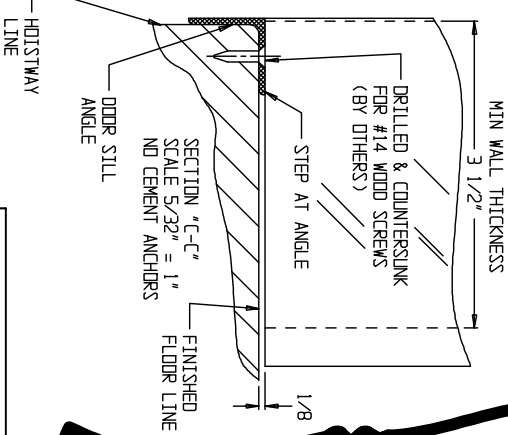
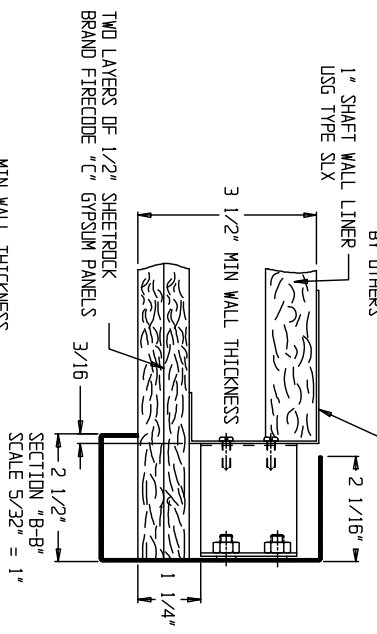

HOISTWAY TO BE BUILT BEFORE DUMBWATER IS INSTALLED EXCEPT THE WALLS ARE TO BE OMITTED WHERE HOISTWAY DOORS OCCUR UNTIL THE DUMBWATER IS INSTALLED & HOISTWAY DOORS ARE SET IN PLACE

L. D. BY		DATE REQ		DWG NO.		JOB NO.	
APPROVED		PAINT		-B-		JJP	
DATE L. D.		SHEET 1 OF 1		1000-725		1000-725	
SCALE 1/16" = 1"		# REQ'D		1000-725		1000-725	
TITLE: TYPICAL VARIATION OF DRYWALL CONSTRUCTION WITH KAFKA UL LABELED FLOOR LOADING BI PARTING				LEVEL 3			
DUMBWATER DOOR				1/9/06			

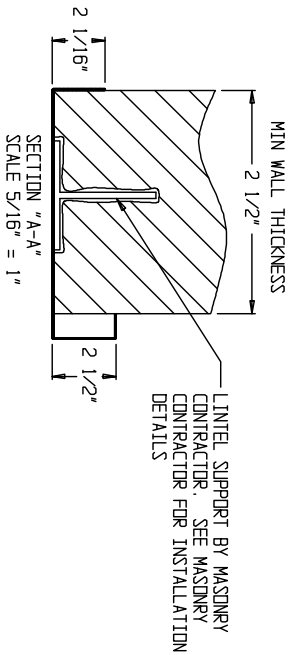

NOTE: AS WALL THICKNESS CHANGES, THE METHOD OF MASONRY INSTALLATION WILL CHANGE ACCORDINGLY. THIS DRAWING SHOULD BE USED ONLY AS A REFERENCE.

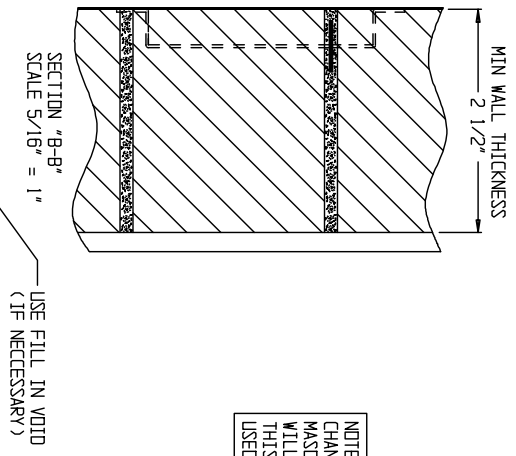

ONLY DOOR FRAME IS SHOWN IN SECTION DETAILS FOR SIMPLICITY

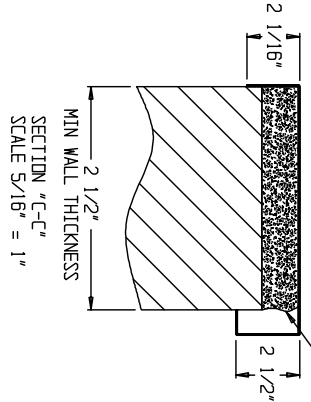

HOISTWAY TO BE BUILT BEFORE DUMBWATER IS INSTALLED EXCEPT THE WALLS ARE TO BE OMITTED WHERE HOISTWAY DOORS OCCUR UNTIL THE DUMBWATER IS INSTALLED & HOISTWAY DOORS ARE SET IN PLACE

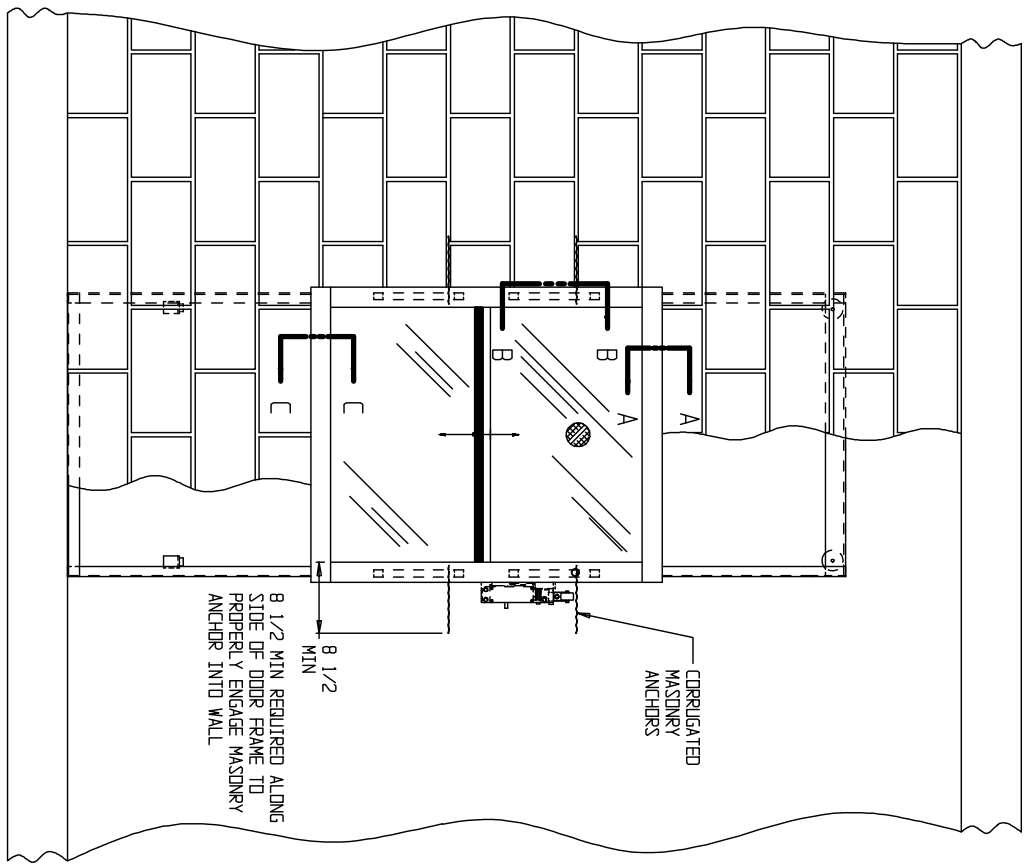

TITLE: TYPICAL VARIATION OF MASONRY CONSTRUCTION WITH KAFKA UL LABELED COUNTER LOADING BI PARTING LEVEL 2
DUMBWATER DOOR 1/9/06

L.O. BY	DATE REQ		DWG NO. 1000-725 JJP	JOB NO.
APPROVED	PAIN'T			
DATE L.O.	SHEET 1 OF 1			
SCALE 1/16" = 1"	# REQ'D			

LINTEL SUPPORT BY MASONRY CONTRACTOR. SEE MASONRY DETAILS FOR INSTALLATION

NOTE: AS WALL THICKNESS CHANGES, THE METHOD OF MASONRY INSTALLATION WILL CHANGE ACCORDINGLY. THIS DRAWING SHOULD BE USED ONLY AS A REFERENCE.

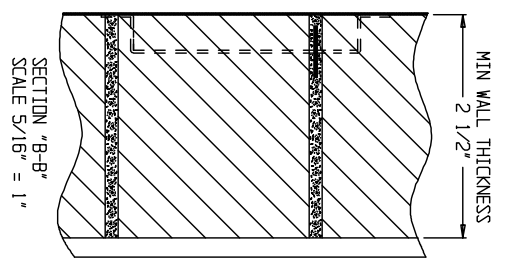
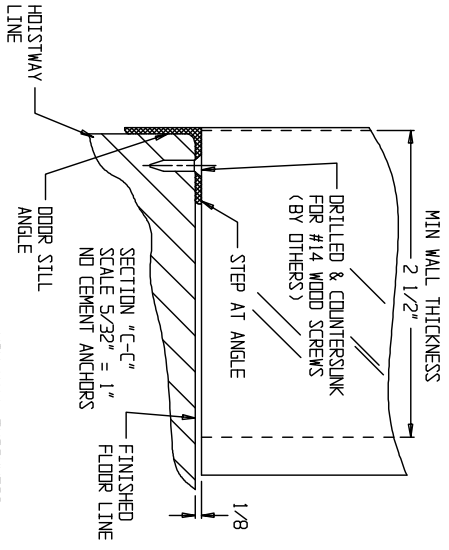
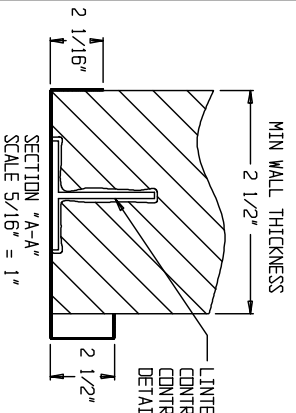

ONLY DOOR FRAME IS SHOWN IN SECTION DETAILS FOR SIMPLICITY

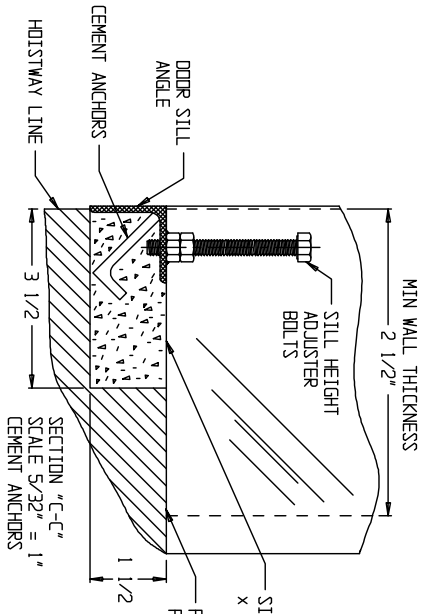

SILL POCKET 3 1/2 x 1 1/2 x FULL WIDTH OF HOISTWAY

HOISTWAY TO BE BUILT BEFORE DUMBWATER IS INSTALLED EXCEPT THE WALLS ARE TO BE OMITTED WHERE HOISTWAY DOORS OCCUR UNTIL THE DUMBWATER IS INSTALLED & HOISTWAY DOORS ARE SET IN PLACE

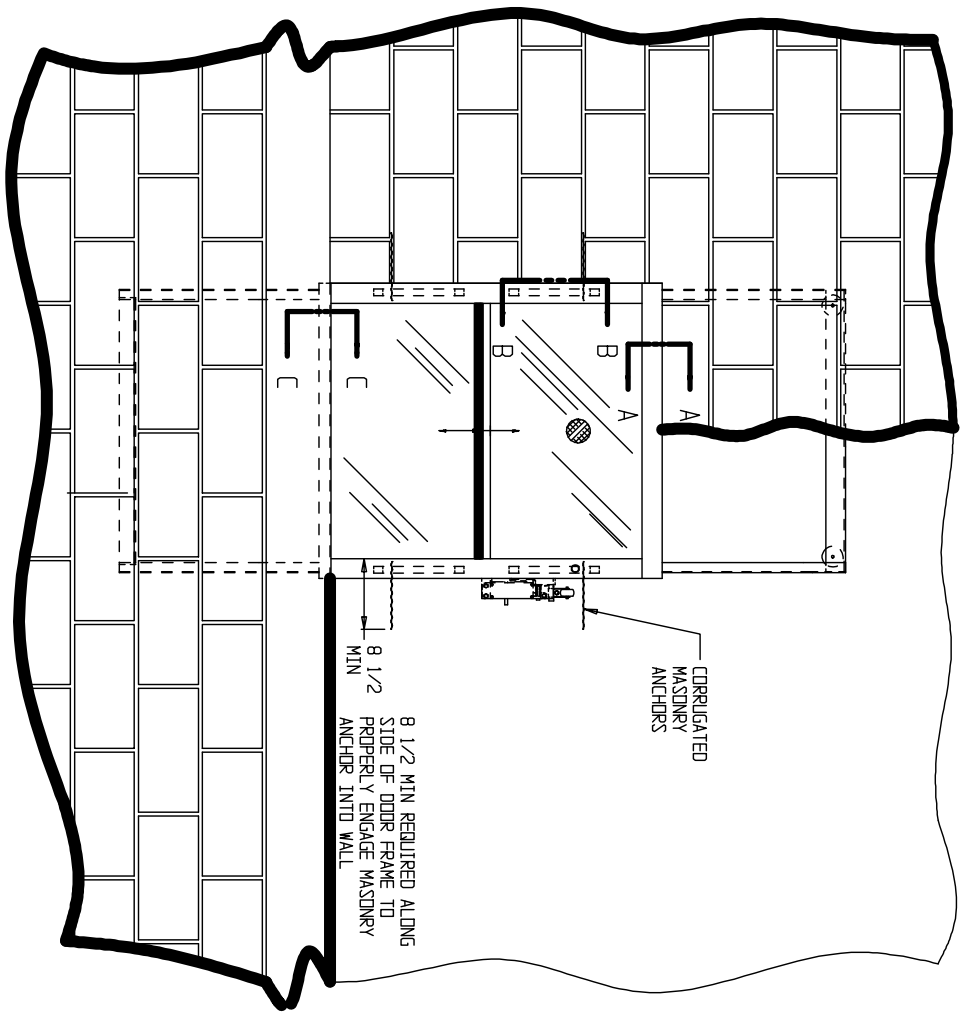

8 1/2 MIN REQUIRED ALONG SIDE OF DOOR FRAME TO PROPERLY ENGAGE MASONRY ANCHOR INTO WALL

TITLE: TYPICAL VARIATION OF MASONRY CONSTRUCTION WITH KAKKA UL LABELED FLOOR LOADING BI PARTING LEVEL 4

L.D. BY	DATE REQ	INCLINATOR COMPANY OF AMERICA HARRISBURG, PA	DWG NO. 1000-725 JJP	JOB NO.
APPROVED	PAINIT			
DATE L.D.	SHEET 1 OF 1			
SCALE 1/16" = 1"	# REQ'D			

BUTTON VOLTAGE
24 V.A.C.

ARRIVAL LIGHT
24 V.A.C.

WALL CONSTRUCTION
DRYWALL | MASONRY

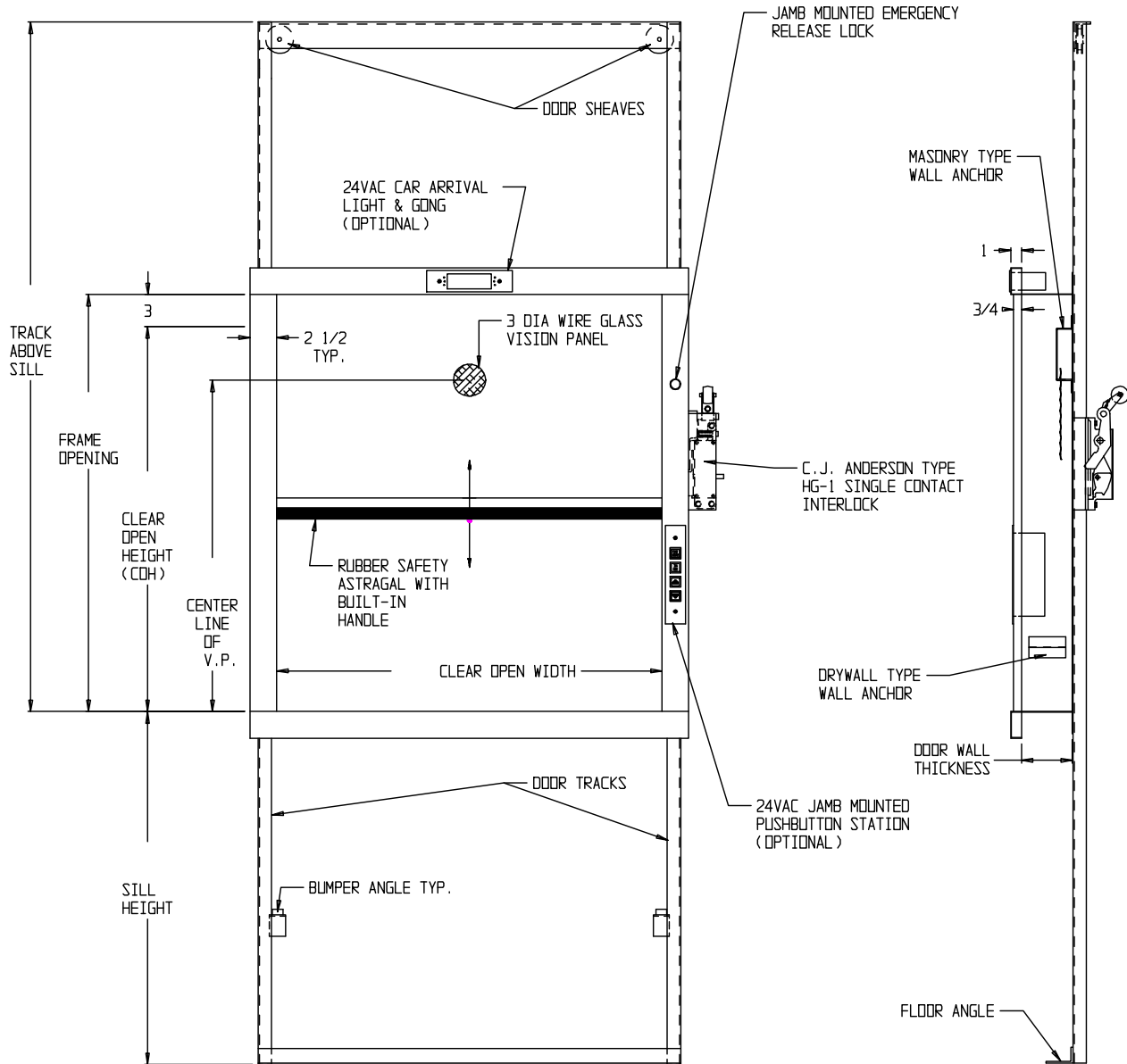

EQUATIONS

TRACK ABOVE SILL=(COH/2)+COH+7 1/2
MIN. TRACK BELOW SILL=(COH/2)+2 1/2
CENTERLINE OF V.P.=FRAME OPENING-8

MATERIAL: 16 GA. STAINLESS STEEL - #4 FINISH OR 16 GA. PRIMED PLAIN STEEL

JOB NAME	CUSTOMER	REVISIONS			
		SYM.	DATE	DESCRIPTION	BY
SHIP TO	TITLE: DUMBWAITER UL "B" LABELED BI-PARTING COUNTER LOADING DOOR				LEVEL 1 2/8/06
	L.O. BY	DATE REQ			
	APPROVED	PAIN			
	DATE L.O.	SHEET OF			
	SCALE 3/32" = 1"	# REQ'D			
			-B-	DWG NO. JJP 1000-709	JOB NO.

BUTTON VOLTAGE
24 V.A.C.

ARRIVAL LIGHT
24 V.A.C.

WALL CONSTRUCTION
DRYWALL | MASONRY

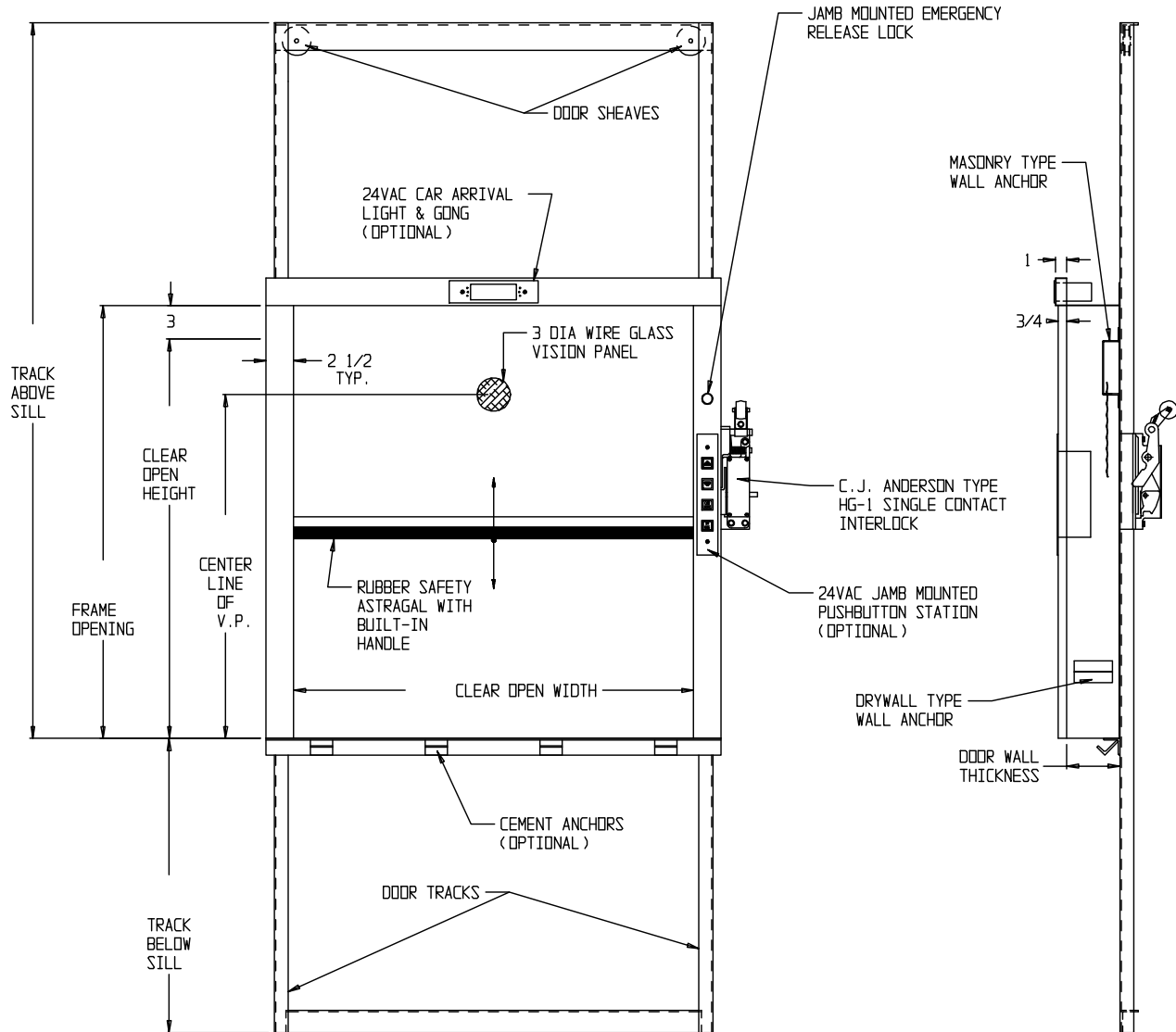

EQUATIONS

TRACK ABOVE SILL=(COH/2)+COH+7 1/2
 TRACK BELOW SILL=(COH/2)+2 1/2
 CENTERLINE OF V.P.=FRAME OPENING-8

MATERIAL: 16 GA. STAINLESS STEEL - #4 FINISH OR 16 GA. PRIMED PLAIN STEEL

JOB NAME	CUSTOMER	REVISIONS			
		SYM.	DATE	DESCRIPTION	BY
SHIP TO	TITLE: DUMBWAITER UL "B" LABELED BI-PARTING FLOOR LOADING DOOR				LEVEL 2 2/8/06
	L.O. BY	DATE REQ			
	APPROVED	PAIN			
	DATE L.O.	SHEET OF			
	SCALE 3/32" = 1"	# REQ'D			
			-B-	DWG NO. JJP 1000-709	JOB NO.

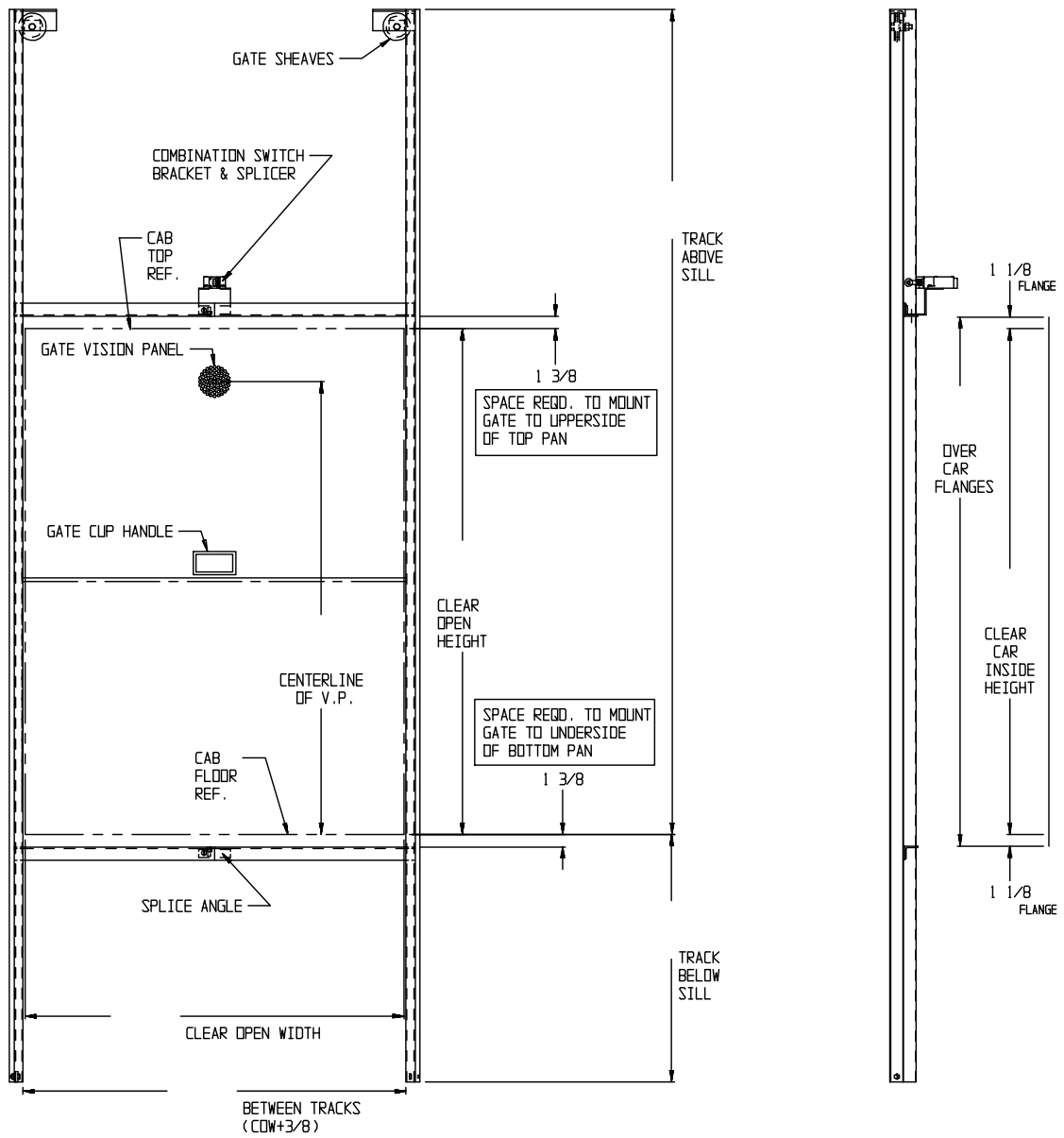

EQUATIONS

$TRACK\ ABOVE\ SILL = (CDH/2) + CDH + 6\ 5/16$
 $TRACK\ BELOW\ SILL = (CDH/2) + 1\ 1/4$
 $CENTERLINE\ OF\ V.P. = CDH - 5$

MATERIAL: 16 GA. STAINLESS STEEL - #4 FINISH OR 16 GA. PRIMED PLAIN STEEL

JOB NAME		CUSTOMER		REVISIONS			
		SYM.	DATE	DESCRIPTION		BY	
SHIP TO		TITLE: DUMBWAITER SINGLE OPENING BI-PARTING MANUAL GATE TRACK ASSEMBLY				LEVEL 1 8/24/05	
L.O. BY JJP		DATE REQ					
APPROVED		PAINT					
DATE L.O.		SHEET OF					
SCALE 3/32" = 1"		# REQ'D					
		-B-		DWG NO. 1000-430		JOB NO.	

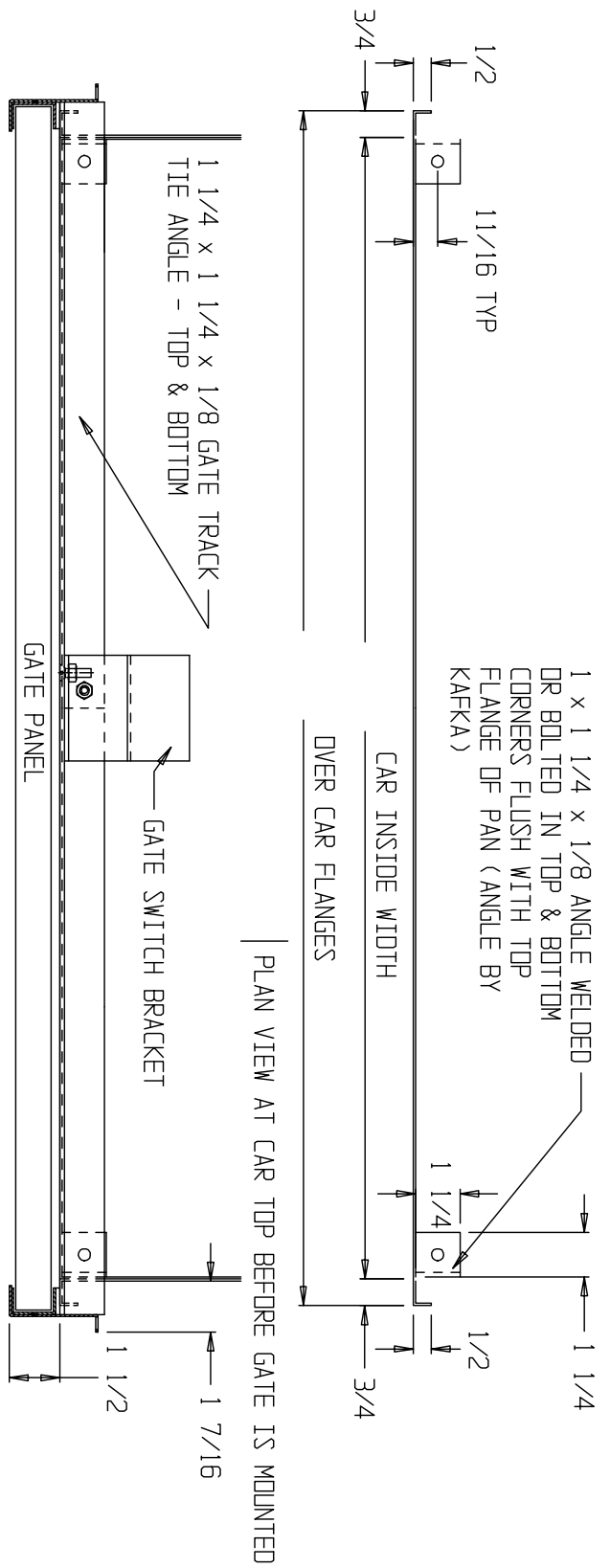

FOR REFERENCE ONLY

PLAN VIEW AT CAR TOP AFTER GATE IS MOUNTED

JOB NAME CUSTOMER REVISIONS

SYM.	DATE	DESCRIPTION	BY

SHIP TO TITLE: PLAN VIEW AT CAR TOP OF BI-PARTING CAR GATE FOR INCLINATOR DUMBWAITER LEVEL 1
8/24/05

L.O. BY	DATE REQ	<p style="text-align: center;">INCLINATOR COMPANY OF HARRISBURG, PA  AMERICA</p>
APPROVED	PAINT	
DATE L.O.	SHEET	
SCALE N.T.S.	# REQ'D	

-A- DWG NO. 1000-428 JOB NO.
JJP