

ORDER REFERENCE

PROJECT: 200# DUMBWAITER
MACHINE BELOW

TYPICAL DRAWING FOR REFERENCE ONLY
NOT TO BE USED FOR CONSTRUCTION

SPECIFICATIONS

MODEL: DW-200 (COLLAPSIBLE GATE WITH SWING DOOR)

LANDINGS: 2

CODE(S): 4,5

CAPACITY: 200#

SPEED: 33 F.P.M.

SUSPENSION MEANS: 1 WIRE ROPE 5,400 LBS. EHS
STEEL 1/4" x 8 x 19 IWRC

CAR CONSTRUCTION: STAINLESS STEEL
OR PAINTED STEEL

NOTE: ALL MANUFACTURER SUPPLIED CAR AND EQUIPMENT OPTIONS ARE NOTED ON THE CONFIRMING ORDER SHEET.

DISCLAIMER: ONCE DRAWINGS HAVE BEEN APPROVED, SIGNED AND WITHIN 5 DAYS OF PRODUCTION, THE CUSTOMER WILL BEAR ALL RESPONSIBILITY AND LIABILITY OF FINISHED UNIT.

PLEASE REFER ANY QUESTION TO YOUR SALES REPRESENTATIVE

APPROVED

UNAPPROVED

SIGNATURE

DATE

DWG VIEW	PART NUMBER	REV. DATE
COVER SHEET	TYPICAL	—
 DRAWING TITLE	DRAWING NO.	—
DW 200 CODE 4,5 MR BELOW	DW-005	—
PAGE:	DRAWN BY:	DWG. DATE
1/4	B. BRATTEN	JAN. 2014
JOB OR APP.#	DEALER P.O.#	DWG. SCALE
—	—	1:24
REV. LEVEL (1-3)		—

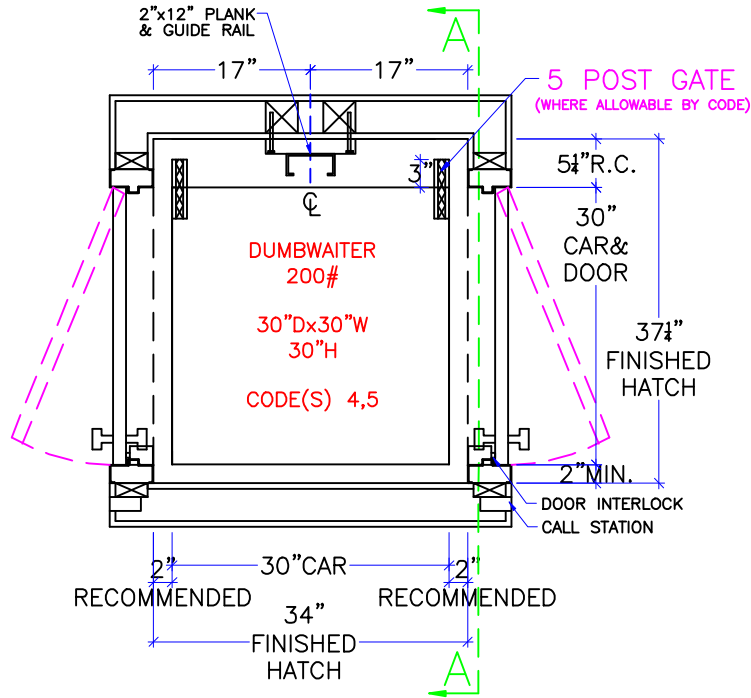

HOISTWAY PLAN

SEE "LOAD CAPACITY CALCULATOR"
FOR OTHER POSSIBLE
DW 200# CAB DIMENSIONS

NOTE:
ALL HOISTWAY CONSTRUCTION MUST COMPLY WITH NATIONAL, STATE,
AND LOCAL CODES. HOISTWAY MUST BE PLUMB AND STRAIGHT FROM
TOP TO BOTTOM WITH NO PROJECTIONS INTO THE HOISTWAY.

NOTICE TO ELECTRICAL CONTRACTOR:

208V SERVICE REQUIRES A BUCK BOOST TRANSFORMER BY OTHERS

- ALL ELECTRICAL WIRING MUST BE DONE BY A JOURNEYMAN MECHANIC AND MUST MEET ALL NATIONAL, STATE, AND LOCAL CODES.
- BRING (3) #12 W/GND FROM RESIDENCE INCOMING POWER PANEL 20AMP BREAKER(240V, NEUTRAL, GROUND)TO THE MACHINE ROOM.
- BRING (2) #12 W/GND FROM RESIDENCE INCOMING POWER PANEL 20AMP GFI BREAKER(120V, NEUTRAL, GROUND)TO THE MACHINE ROOM.
- REQUIRED LOW VOTAGE WIRING IS SUPPLIED BY MANUFACTURER. ALL EXTENSIONS ADDITIONS, ETC. SHALL BE DONE WITH THE SAME SIZE AND TYPE OF WIRE AS ORIGINALLY SUPPLIED BY THE MANUFACTURER.
- ALL MEANS FOR ACCESS TO EQUIPMENT SHALL BE PROVIDED WITH A LOCK. ALL SHAFT DOORS MUST BE INTERLOCKED.

<p>DWG VIEW HOISTWAY LAYOUT</p>	<p>PART NUMBER TYPICAL</p>	<p>REV.DATE -</p>
<p>DRAWING TITLE DW 200 CODE 4,5 MR BELOW</p>	<p>DRAWING NO. DW-005</p>	<p>-</p>
<p>PAGE: 2/4</p>	<p>DRAWN BY: B.BRATTEN</p>	<p>REV.LEVEL(1-3) -</p>
<p>DWG. DATE JAN. 2014</p>	<p>JOB OR APP.# -</p>	<p>DWG. SCALE 1:24</p>
<p>DEALER P.O.# -</p>	<p>DWG. SCALE 1:24</p>	<p>REV.LEVEL(1-3) -</p>



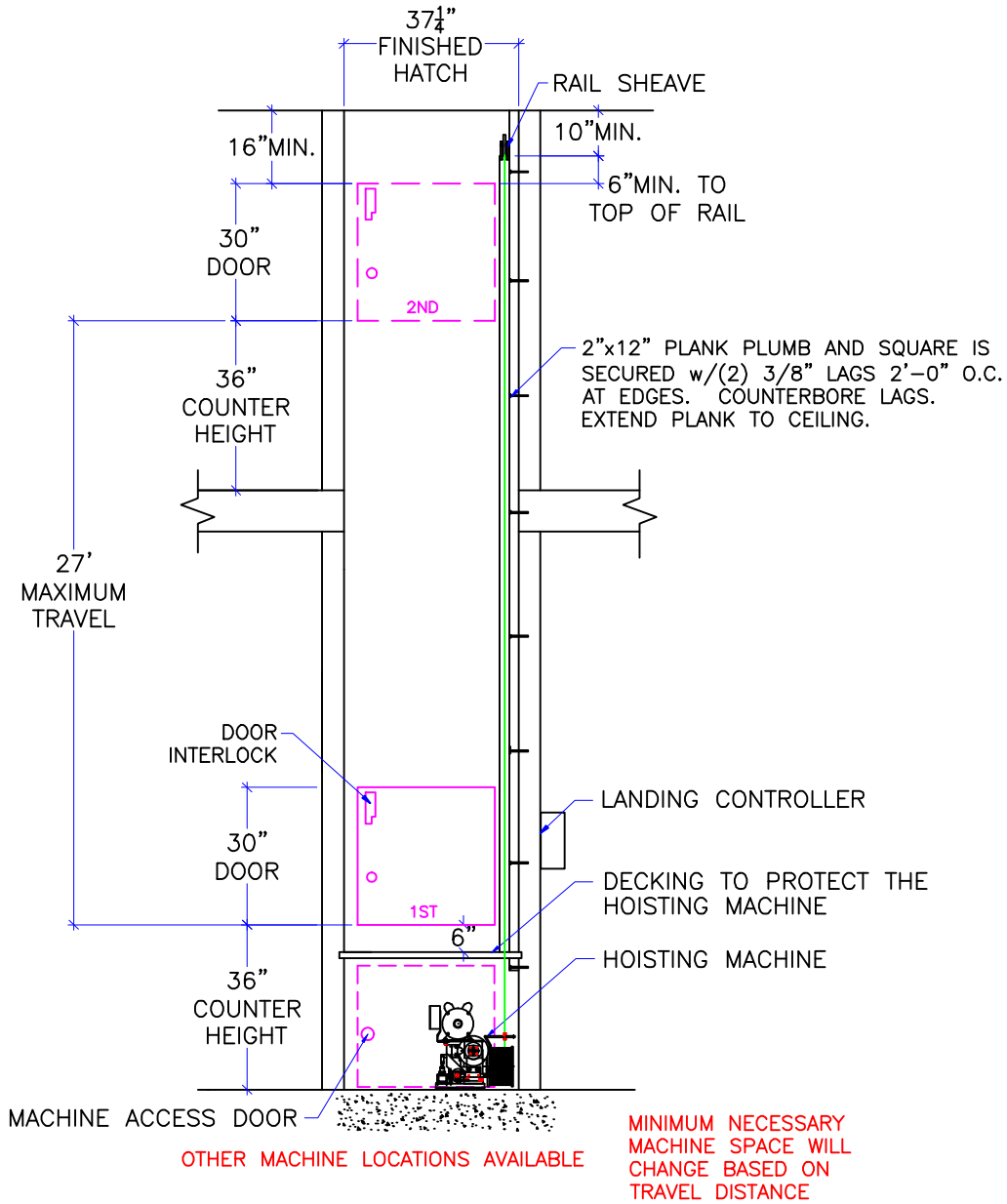

SECTION A-A

DWG VIEW		SECTION A-A			PART NUMBER		REV. DATE
					TYPICAL		-
		DRAWING TITLE			DRAWING NO.		-
		DW 200 CODE 4.5 MR BELOW			DW-005		-
PAGE:	DRAWN BY:	DWG. DATE	JOB OR APP.#	DEALER P.O.#	DWG. SCALE	REV. LEVEL(1-3)	
3/4	B. BRATTEN	JAN. 2014	-	-	1:24	-	

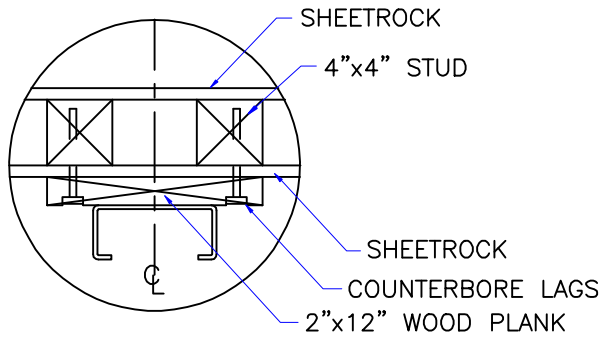

NOTE:
WHEN STUD AND SHEETROCK CONSTRUCTION IS USED ON THE GUIDE RAIL SUPPORT WALL 4"x4" STUDDING IS NEEDED BEHIND THE 2"x12" PLANK.

RAIL DETAIL

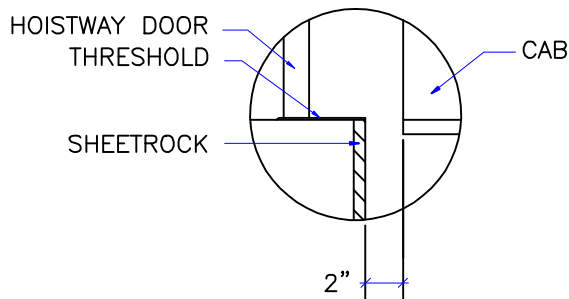

DOOR SILLS TO BE INSTALLED BY G.C. AFTER LIFT SUPPLIER HAS INSTALLED A RUNNING PLATFORM.

SILL DETAIL

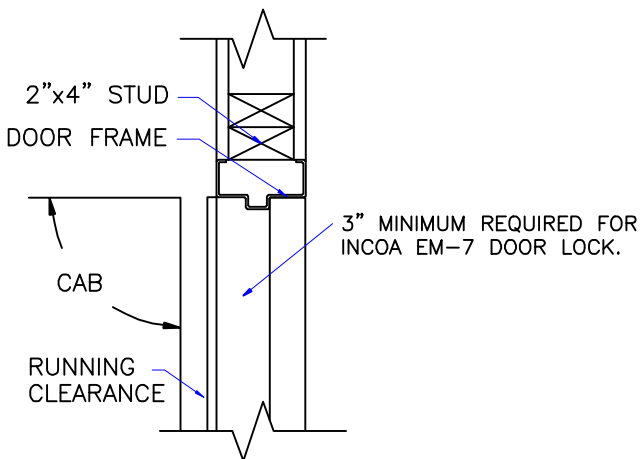

DOOR FRAME DETAIL

SEE "LOAD CAPACITY CALCULATOR" FOR OTHER POSSIBLE DW 200# CAB DIMENSIONS

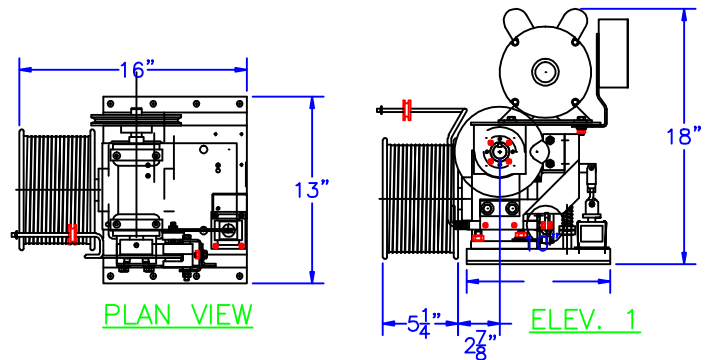

1. MACHINE ROOM SIZE REQUIREMENTS MAY CHANGE WITH TRAVEL DISTANCE

2. MACHINE ROOM CAN BE LOCATED ABOVE OR BELOW HOISTWAY

3. SHEAVE COMBINATIONS WILL CHANGE WITH ALTERNATE MACHINE ROOM LOCATIONS

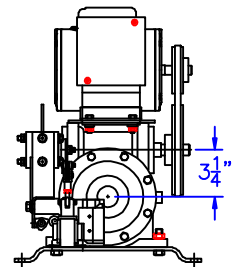

ELEV. 2

200# DUMBWAITER MACHINE DIMENSIONS

1. REACTIONS ON ALL SHEAVES AND MOUNTINGS
STATIC = 600 LBS.
IMPACT = 1,200 LBS.
2. RAIL FASTENING TO 2" x 12" PLANK
#14 x 1 3/4" TYPE A S.M.S. RAIL IS PRE-DRILLED AT FACTORY.
3. BOLT FASTENING OF CAR TO TROLLEY
1/2" - 13 x 2 1/2" SOCKET HD CAP SCREWS.

TECHNICAL DATA

DWG VIEW

DETAILS, DATA, CODES

PART NUMBER

TYPICAL

REV. DATE



DRAWING TITLE

DRAWING NO.

-

DW 200 CODE 4.5 MR BELOW

DW-005

-

PAGE:
4/4

DRAWN BY:
B. BRATTEN

DWG. DATE
JAN. 2014

JOB OR APP.#
-

DEALER P.O.#
-

DWG. SCALE
1:24

REV. LEVEL(1-3)
-